

Vortex

12 Channel Gas and Fire Control Panel



Installation, Operation and Maintenance Manual

M07211
Issue 8
January 2015

Important Notes:

The equipment described in this manual may have mains voltages applied to it. Ensure correct safety procedures are adopted before working on the equipment.

The equipment described in this manual is designed for the detection of flammable and/or toxic gases. Detectors may be sited in hazardous areas. Ensure local safety procedures are adopted before carrying out any maintenance or calibration work.

The equipment described in this manual may be connected to remote alarms and/or shutdown systems. Ensure that local operating procedures are adopted before carrying out any maintenance or calibration work.

TABLE OF CONTENTS

1 INTRODUCTION.....	7
1.1 What this manual is for.....	7
1.2 What is Vortex?	7
1.3 Who should use this manual.....	7
1.4 What this manual contains	8
2 SYSTEM OVERVIEW.....	9
2.1 General	9
2.2 System description.....	9
2.2.1 System modules and options	9
2.2.2 Input/output capability.....	10
2.2.3 Digital Communications.....	11
2.2.4 Specification.....	11
2.2.5 Approvals	12
3 INSTALLATION.....	13
3.1 General	13
3.2 Before installation	13
3.3 Installation of a pre-configured Vortex system	14
3.4 Installation of an un-configured Vortex system.....	15
3.4.1 General	15
3.5 Building a Vortex system.....	16
3.5.1 Building the system	16
3.5.2 Installing the system.....	17
3.6 Cabling.....	18
3.7 Circuit Breaker	19
3.8 Zero adjustment and calibration of Vortex.....	19
3.8.1 General	19
3.8.2 Zero Adjustment and Calibration procedure.....	20
4 TECHNICAL INFORMATION: VORTEX.....	21
4.1 General	21
4.2 Node Controller Module	21
4.2.1 Functions of the Node Controller Module	21
4.2.2 Node Controller Module indicators, switches and connectors	22
4.2.3 Configuring the Node Controller Module	23

4.3 The Bus Rail and electrical connections	24
4.4 Quad Channel Input Module	25
4.4.1 Functions of the Quad Channel Input Module.....	25
4.4.2 Configuring the Quad Channel Input Module.....	26
4.5 Relay Output Module	29
4.5.1 Functions of the Relay Output Module.....	29
4.5.2 Configuring the Relay Output Module.....	30
4.5.3 Configuring the Relay Logic.....	35
4.6 The Display Module	36
4.6.1 Functions of the Display Module.....	36
4.6.2 Display Module Features.....	38
4.7 Power Monitoring Module	40
4.7.1 Functions of the Power Monitoring Module.....	40
4.7.2 Removing the 5-Way Cable Assembly.....	42
4.7.3 Mounting the Power Monitoring Module on a DIN Rail.....	42
4.7.4 Backup batteries.....	43
4.7.5 Power Failure.....	44
5 TECHNICAL INFORMATION: FIELD DEVICES	44
5.1 General	44
5.2 Gas Detectors	44
5.2.1 Gas detector location.....	44
5.3 Fire detectors	45
5.3.1 Fire detector location.....	46
5.4 Connections for audible/visual alarms	46
6 OPERATION	47
6.1 General	47
6.2 Monitoring with the Display Module	47
6.3 Alarm conditions and faults	48
6.3.1 Display Module.....	48
6.3.2 Internal sounder and relays.....	48
6.4 Fault Messages	49
6.4.1 Channel Faults.....	49
6.4.2 Power Status.....	50
6.4.3 System Faults.....	50
7 MAINTENANCE	51
7.1 Detector Functional Testing	51
7.2 Inhibiting input	51

7.3 Re-calibration of Vortex	52
7.4 Channel Test Mode	53
7.4.1 Channel Test Mode procedure	53
7.4.2 Setting alarm levels	55
7.5 Lamp test	55
7.6 Event logging	56
7.7 Module replacement	57
7.8 Mounting and dismounting DIN Rail modules	58
7.9 Changing the Batteries	58
APPENDIX A: GLOSSARY	60
APPENDIX B: ELECTRICAL CONNECTIONS	62
APPENDIX C: LIST OF SPARE PARTS	66
APPENDIX D: CROWCON DETECTOR RANGE	67
APPENDIX E: VORTEX CONFIGURATION	69
APPENDIX F: EARTHING	71
Introduction	71
Definitions	71
Questions	71
Diagrams	73
Diagram 1	73
Diagram 2	73
Diagram 3	74
Diagram 4A	76
Diagram 4B	76
Diagram 5A	77
Diagram 5B	77
Wiring Standards	78

TABLE OF FIGURES

Figure 1 : General Assembly of Vortex Modules	10
Figure 2: Vortex system in Standard Enclosure.....	15
Figure 3: Node Controller Module.....	22
Figure 4: Bus Rail Assembly Details	24
Figure 5: Quad Channel Input Module	25
Figure 6: Switches on Quad Channel Input Module	26
Figure 7: Relay Output Module	29
Figure 8: Relay Output Module Selection Switch	31
Figure 9: Back of Display Module	36
Figure 10: Front of Display Module	37
Figure 11: Power Monitoring Module	40
Figure 12: Alternative mountings for the Power Monitoring Module.....	43
Figure 13: Representation of a fire detection circuit.....	46
Figure 14: Module on DIN Rail, and method of removal	58
Figure 15: Removing batteries from Vortex Standard Enclosure	59
Figure 16: Connection schematic for the Vortex system.....	62
Figure 17: Wiring diagram for the Node Controller Module.....	63
Figure 18: Wiring diagram for the Quad Channel Input Module.....	64
Figure 19: Wiring diagram for the Relay Output Module	65
Figure 20 Decision Tree for determining Earthing Requirements.....	72

LIST OF TABLES

Table 1: Vortex options.....	7
Table 2: Which sections of this manual to read	8
Table 3: List of Vortex modules.....	9
Table 4: Vortex Specification	11
Table 5: Cable characteristics.....	18
Table 6: Node Controller Module indicators, switches and connectors.....	22
Table 7: System Configuration Properties	23
Table 8: Quad Channel Input Module switch settings.....	26
Table 9: Detector channel configurable properties.....	27
Table 10: Features of the Relay Output Module	30
Table 11: Relay Output Module switch settings.....	30
Table 12: Relay configurable properties.....	32
Table 13: Relay output types	33
Table 14: Relay Logic configurable properties	36
Table 15: Display module features.....	38
Table 16: Features of the Power Monitoring Module	41
Table 17: List of channel faults.....	49
Table 18: List of Power Status LED codes.....	50
Table 19: List of Node Controller Module LED fault codes	50
Table 20: Channel test display sequences	54
Table 21: Data recorded in the Event Log.....	56

1 INTRODUCTION

1.1 What this manual is for

This manual describes the installation, configuration and operation of the Vortex gas and fire detection system and its components.

Some of the functionality described in this manual may not be available with some units. Contact Crowcon concerning upgrades of existing systems, if required.

1.2 What is Vortex?

Vortex is a modular gas and fire detection system, designed to monitor remote 4-20mA and conventional loop powered fire detectors. Other devices may be used as advised by Crowcon. It can operate flexibly assigned and voted relays if pre-set levels of gas are exceeded or if smoke or fire is detected. These relay outputs may be used to drive audible and/or visible alarms. The built-in Modbus communications interface allows multiple Vortex systems to be connected to industry-standard control monitoring systems.

The Vortex system may be mounted in a variety of enclosure; the options are listed in Table 1

Table 1: Vortex options

Vortex.	Standard wall-mounted enclosure with display See Figure 2: Vortex system in Standard Enclosure.
Vortex Rack*	Vortex system with a 19-inch rack-mounted display.
Vortex Panel*.	Vortex system with a panel-mounted display
Vortex DIN*	Vortex system with no display.

Options marked * can be supplied as modules to be mounted in your own enclosure.

The system can be supplied pre-configured with detectors and output devices, the configuration is summarised on the Specification Sheet provided with the system. The configuration can be modified using the VortexPC software.

1.3 Who should use this manual

You may not need to read the whole of this manual. You will be guided to the sections that you require.

You should consult this manual if you:

- Use the Vortex system for monitoring fire or gases, and respond to alarms
- Carry out routine maintenance on the Vortex system and its detectors
- Configure the Vortex system

- Install the Vortex system and its detectors
- Require technical information on Vortex

1.4 What this manual contains

This manual covers the following topics:

- An overview of the Vortex system
- Installation of Vortex systems ready configured and supplied with detectors
- Installation and configuration of Vortex to work with your own detectors
- Installation of Vortex when supplied as modules for mounting in your own equipment
- Configuration and technical information
- Day-to-day operation of Vortex, and accepting alarms and faults
- Routine maintenance, recalibration and testing

Table 2 lists the sections to read for particular kinds of information. If you require details not covered in this manual, please contact Crowcon Technical Support.

Table 2: Which sections of this manual to read

If you	Refer to
Use the Vortex system for monitoring fire or gases, and respond to alarms	Chapter 6
Carry out routine maintenance and testing on the Vortex system and its detectors	Chapters 2 and 7, and references to other sections
Install, calibrate and reconfigure a Vortex system	Chapters 2 to 5

2 SYSTEM OVERVIEW

2.1 General

This chapter gives an overview of the Vortex system, its modules and their interconnection. Vortex can be supplied in a number of variations depending on the modules and enclosures required.

If you simply use Vortex for monitoring and responding to alarms, it is not necessary to read this chapter. See chapter 6, *Operation*.

In all other cases, we recommend that you read this section.

2.2 System description

2.2.1 System modules and options

The basic parts of the Vortex system are listed in Table 3. Some are optional. The essential components are marked with an asterisk (*).

Table 3: List of Vortex modules

Module	Description
*Node Controller Module	Central control module of system between modules.
.*Bus Rail	Electrical connections and communications Modules
*Quad Channel	Input Control and measurement of input, up to 4channels per module, maximum 3 modules.
Relay Output Module	Control of output, up to 8 channels per module, maximum 4 modules.
Display Module	User display and limited configuration
.*Power Monitoring. unit	Control and protection of power supply
Module Mains power supply	If the Mains Power Supply Unit is omitted, a suitable dc power supply must be provided.

Figure 1 shows the general assembly of the modules within the Vortex system. The number and arrangement of the modules will vary depending on your Vortex system configuration.

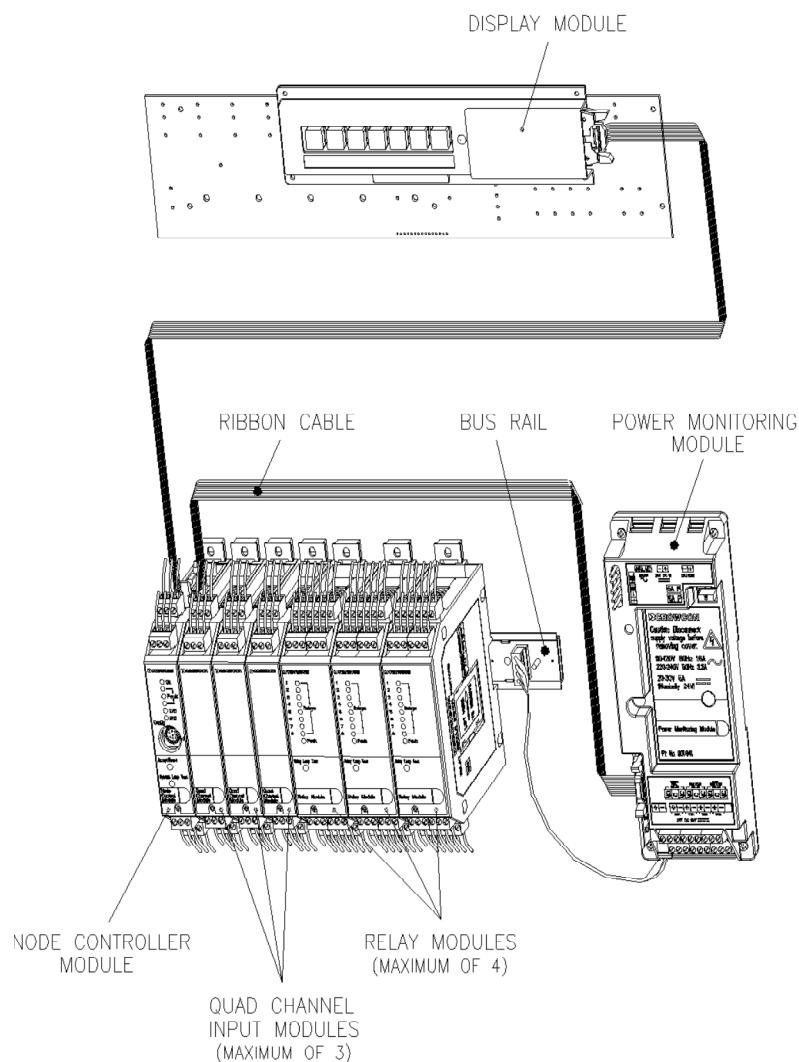

Figure 1: General Assembly of Vortex Modules

2.2.2 Input/output capability

The Vortex system is a control panel for gas and fire detectors. It can be used with the following detectors:

- 2 wire sink, or 3 wire sink or source 4-20mA detectors. Crowcon manufactures a wide range of flammable and toxic gas detectors and oxygen detectors. See Appendix D for the Crowcon range. The detectors of many other manufacturers can also be used, including 4-20mA fire detectors, however the behaviour of these detectors should not be confused with that of the conventional loop powered fire detectors referred to throughout this manual as Fire Detectors.
- Conventional loop-powered fire detectors and manual call points (up to twenty devices) with a maximum loop current of 60mA. Only 1 fire loop may be connected to each Quad Channel Input Module. Vortex has been tested for use with the Apollo range of conventional smoke/heat detectors. Other manufacturers' detectors or other devices such as flame detectors may also be used. Contact Crowcon for further details.

Vortex can control up to 32 fully voted relay outputs, selectable from a number of channel and system functions. The Quad Channel Input Modules and Relay Output Modules (section 2.2.1) can be combined as follows:

	Number of Quad Channel Input Modules	Maximum number Relay Output Modules
Vortex	Up to 3	3
	Up to 2	4
Vortex DIN Vortex Rack Vortex Panel	Up to 3	4

2.2.3 Digital Communications

There is an RS232 configuration port on the Node Controller Module which may be used together with the VortexPC software running under the Microsoft® Windows® operating system to configure the system.

There is an RS485 Modbus port that can be used by personal computers, Programmable Logic Controllers and Distributed Control Systems to monitor the Vortex system.

2.2.4 Specification

The Vortex system specification is listed below.

Table 4: Vortex Specification

Storage temperature	-25 to +55 degrees C
Operating temperature	-10 to +40 degrees C
Humidity	0 to 99% relative humidity, non-condensing at 40 degrees C
Ingress Protection	Vortex – IP65 Vortex Panel – The display and label fixing meets IP65 but the overall rating depends on the remainder of the enclosure. For Vortex DIN and Vortex Rack the rating depends on the enclosure used.
Impact	Able to withstand normal wear and tear associated with installation
Safety	The control system is not intended for use in hazardous areas. Earthing for use with IS detectors is discussed in Appendix F.

Power supply voltage	Vortex 20-30V dc 5A 110-120V ac 60Hz 3.2A 220-240V ac 50Hz 1.6A Other Vortex systems are dependent on the size of the system and PSU fitted
Backup batteries	Vortex: Two series 12V, 2Ah batteries. Larger capacity backup systems are available. Other Vortex systems are dependent on the size of the system and PSU fitted.

2.2.5 Approvals

Vortex complies with the following:

- Low Voltage Directive EN61010-1, Safety requirement for electrical equipment for measurement, control and laboratory use, Part 1.
- EMC EN50270, Electromagnetic Compatibility – Electrical apparatus for the detection and measurement of combustible gases, toxic gases and oxygen.

3 INSTALLATION

3.1 General

This chapter describes the installation procedures for Vortex together with associated detectors and output devices.

If you simply use Vortex for monitoring and responding to alarms, it is not necessary to read this chapter. See chapter 6, *Operation*.

3.2 Before installation

Before installing a Vortex system along with its field devices, ensure that you have read the instructions in this chapter, and that you understand the use of the Display Module push-buttons and/or the VortexPC software where they are relevant to your installation. See section 4.6 for details of the Display Module functions.

Each field device has its own Installation, Operating and Maintenance Instructions. Please refer to the instructions provided with the devices installed with your system.

Local regulations and installation practices for electrical equipment vary from country to country.

Ensure that you are familiar with those that apply locally before you use this manual to install or use a Vortex system. Further advice is available from Crowcon if required.

The Vortex system is intended for use in non-hazardous areas. Field devices may be mounted in flammable atmospheres. Check that the equipment to be installed is suitable for the area classification.

Site procedures should be followed in attempting installation or maintenance of any field device.

Crowcon recommends that the installation of a Vortex system be carried out by people with experience of installing electrical equipment in potentially hazardous areas. Advice on earthing requirements can be found in Appendix F.

Vortex is suitable for use in a range of environments. See 2.2.4 for details. If a Vortex unit is fitted outside and may be subjected to excessive heating by high levels of direct sunlight, an appropriate shade must be provided.

3.3 Installation of a pre-configured Vortex system

This section describes how to get started with any Vortex system that has been pre-configured for the detectors that were supplied with it.

See the Specification Sheet provided with your system for full details of its configuration.

Figure 1 shows the layout of the modules within the Vortex system. The number and arrangement of the modules will vary depending on your Vortex configuration.

1. Ensure that the power supply is correct for the system (see section 4.3 and Table 16). If your Mains Power Supply Unit has a voltage switch, ensure it is on the correct setting for your mains supply.
2. Ensure that a circuit breaker that complies with regulations is installed for the system power supply. See section 3.7.
3. Place the enclosure or cabinet in its working position. Consider issues of location, cabling, and earthing discussed in sections 3.6 and 5.2 and Appendix F. The standard enclosure is supported on screws through the two top lugs, and held against the wall with the two bottom lugs. (see Figure 2)
4. Install the detectors. See section 5.2.1 for information on gas detector location, and section 5.3.1 for fire detectors.
5. Install the output devices. See section 5.4.
6. Connect the RS485 port to external equipment, as required.
7. If battery backup is installed, insert the battery connector at the top right of the Power Monitoring Module (see Figure 11). This connects the system to the battery backup. Ensure that the Power Monitoring Module is connected to the Bus Rail with the cable. If the battery has enough charge, power-up may occur at this point (see step 8).
8. Connect the external power supply. The green LED on the Power Monitoring Module is illuminated. The system performs a lamp test and audible alarm test within a few seconds. After this test, it is normal for fault conditions to occur because devices are not yet connected. Press ACCEPT/RESET to silence the audible alarm.
9. Connect and power up the detectors one at a time by inserting the terminal plugs into the sockets at the top and bottom of the Quad Channel Input Modules. The wiring diagram is shown in Figure 18, Appendix B.
10. Write the detector locations on the label inside the enclosure or cabinet.
11. Connect the output devices one at a time attaching them to the Relay Output Modules, as shown in the wiring diagram in Figure 19, Appendix B.
12. Ensure that the display is cycling through the channels by pressing the RUN button.
13. Calibrate the detectors, according to the instructions supplied with them.
14. Calibrate the channels on the Quad Channel Input Module, as described in section 3.8.

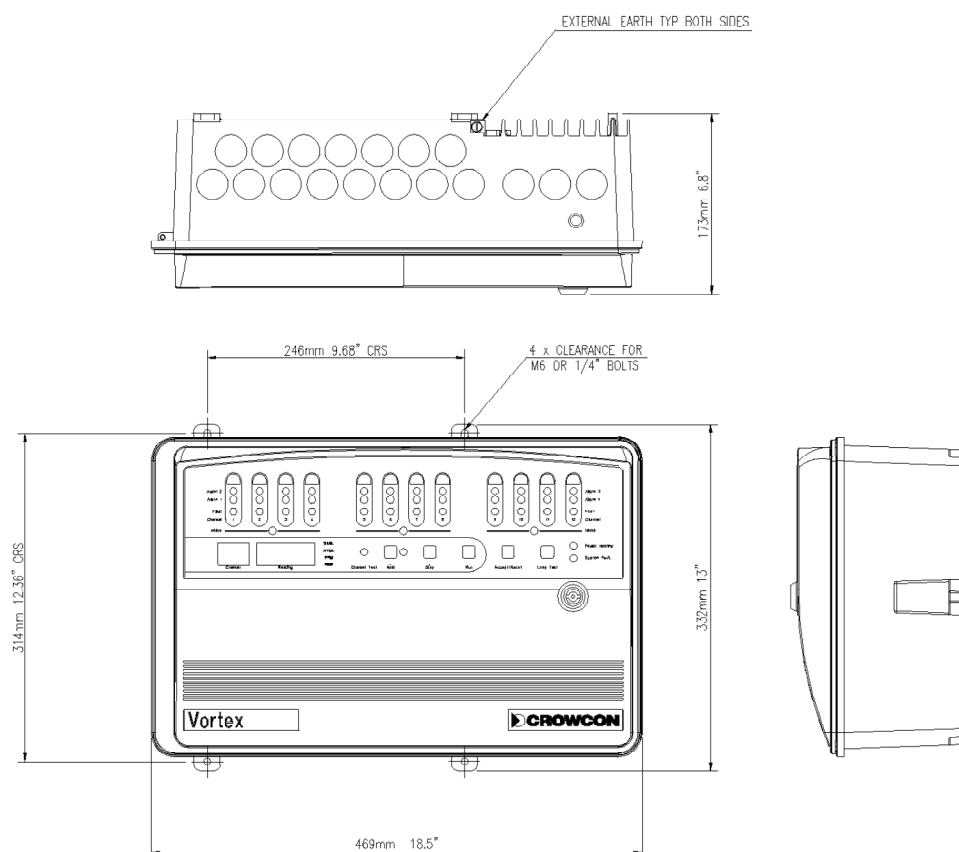

Figure 2: Vortex system in Standard Enclosure

3.4 Installation of an un-configured Vortex system

3.4.1 General

This section describes how to get started if your Vortex system was not supplied ready-configured, and you need to configure it for your own detectors.

It also applies if you wish to reconfigure an existing system, for example, if you are installing new detectors or alarms, or if you are adding new Quad Channel Input Modules or Relay Output Modules to your system, or changing them.

1. Ensure that the power supply is correct for the system (see section 4.3 and Table 16). If your Mains Power Supply Unit has a voltage switch, ensure it is on the correct setting for your mains supply.
2. Ensure that a circuit breaker that complies with regulations is installed for the system power supply. See section 3.7.
Place the enclosure or cabinet in its working position. Consider issues of location, cabling and earthing discussed in sections 3.6 and 5.2 and Appendix F. The standard enclosure is supported on screws through the two top lugs, and held against the wall with the two bottom lugs.
4. Install the detectors. See section 5.2.1 for information on gas detector location, and section 5.3.1 for fire detectors.

5. Install the output devices. See section 5.4.
6. Connect the RS485 port to external equipment, as required.
7. If battery backup is installed, insert the battery connector at the top right of the Power Monitoring Module (see Figure 11). This connects the system to the battery backup. If the battery has enough charge, power-up may occur at this point (see step 8).
8. Connect to the power. The system does a lamp test and audible alarm test. After this test, it is normal for fault conditions to occur because devices are not yet connected. Press ACCEPT/RESET to silence the audible alarm.
9. Connect the system to a PC and configure the system using VortexPC. See VortexPC Help for instructions on how to do this.
10. Configure the Quad Channel Input Module switches. See section 4.4.2 for details. Instructions for removing and mounting modules on the DIN Rail are in section 7.8.
11. Connect and power up the detectors one at a time by inserting the terminal plugs into the sockets at the top and bottom of the Quad Channel Input Modules. The wiring diagram is shown in Figure 18, Appendix B
12. Calibrate each detector according to the instructions supplied with the devices. Calibrate the channels on the Quad Channel Input Module, as described in section 3.8.
13. Write the detector locations on the label inside the enclosure or cabinet.
14. Configure the Relay Output Module switches. See section 4.5 for details. Instructions for removing and mounting modules on the DIN Rail are in section 7.8.
15. Connect and power up the output devices one at a time. Attach them to the Relay Output Modules, as shown in the wiring diagram in Figure 19, Appendix B.
16. Ensure that the display is cycling through the channels by pressing the RUN button.

3.5 Building a Vortex system

This section provides instructions on building and installing a Vortex system inside your own cabinet or racking.

3.5.1 Building the system

1. Assemble the Bus PCB in the DIN Rail, and mount the DIN Rail in the casing. If you are using two DIN Rails, mount them so that they can be connected by the interconnection ribbon cable, which is the ribbon cable with two 10-way connectors.
2. Configure the Quad Channel Input Module switches. See section 4.4.2 for details.
3. Configure the Relay Output Module switches. See section 4.5 for details.
4. Assemble the modules on the Bus Rail(s). To reduce interference with the input channels when switching heavy loads, the Relay Output Modules should be on the right of the Quad Channel Input Modules. The Node Controller Module should be at the left, as in Figure 1. Instructions for mounting and removing modules on the DIN Rail are in section 7.8.
5. **IMPORTANT FOR SAFETY.** If the system is Vortex DIN, Vortex Panel or Vortex Rack and does not use the 5-way cable assembly from the power monitor module to the standard vortex mains power supply unit, then the cable assembly should be removed according to section 4.7.2. Mount the Power Monitoring Module on the DIN Rail according to section 4.7.3.
6. Ensure the power supply is correct for the system (see section 4.3 and Table 16). The Mains Power Supply Unit, if fitted, must be appropriately earthed. If your Mains Power Supply Unit has a voltage switch, ensure it is on the correct setting for your mains supply.

7. The backup batteries, if fitted, must be mounted in an upright position and the safety valves must not be covered. The batteries must not be enclosed in an unventilated space to avoid the build-up of any gas as the result of malfunction.
8. Mount the Display Module in an appropriate position.
 - a. For Vortex Rack this is simply a matter of fixing the display into a 19 inch rack system.
 - b. For Vortex Panel the template supplied should be used to make the holes in the panel. Then the display and associated metal work is fitted to the rear of the panel with countersunk screws. The label is fitted to the front of the panel. Care is required when fitting the label because the adhesive is very strong and any misplacement of the label cannot be corrected without risking the quality of the seal from the label to the panel.
9. Make the electrical connections, as shown in the schematic of Appendix B Figure 16: Connection schematic for the Vortex system. For essential information about earthing, see Appendix F.

Every effort has been made to provide instructions which result in a system that maintains compliance with the LVD and EMC standards (see section 2.2.5).

Ultimately it is the customers responsibility to follow these instructions in order that the final system remains compliant with the standards.

3.5.2 Installing the system

1. Place the system in its working position. Consider issues of location, cabling and earthing discussed in sections 3.6 and 5.2 and Appendix F.
2. Ensure that a circuit breaker that complies with regulations is installed for the system power supply. See section 3.7.
3. Install the detectors. See section 5.2.1 for information on gas detector location, and section 3.6 and 5.3.1 for fire detectors.
4. Install the output devices. See section 5.4.
5. Connect the RS485 port to external equipment, as required.
6. If battery backup is installed, insert the battery connector at the top right of the Power Monitoring Module (see Figure 11). This connects the system to the battery backup. If the battery has enough charge, power-up may occur at this point (see step 7).
7. Connect to the power. The system does a lamp test and audible alarm test. After this test, it is normal for fault conditions to occur because devices are not yet connected. Press ACCEPT/RESET to silence the audible alarm.
8. Connect and power up the detectors one at a time by inserting the terminal plugs into the sockets at the top and bottom of the Quad Channel Input Modules. The wiring diagram is shown in Figure 18, Appendix B. Configure the channels. See section 4.4.2. Calibrate each detector according to the instructions supplied with the devices. Calibrate the channels on the Quad Channel Input Module, as described in section 3.8.
9. Write the detector locations on the label inside the enclosure or cabinet.
10. Connect and power up the output devices one at a time. Attach them to the Relay Output
11. Modules, as shown in the wiring diagram in Figure 19, Appendix B. Configure the relays. See sections 4.5.2 and 4.5.3.
12. Ensure that the display is cycling through the channels by pressing the RUN button.

3.6 Cabling

The cabling of gas detectors, fire detectors and alarms and other output devices is an important matter.

Cabling to a detector must be in accordance with the recognised standards of the appropriate authority in the country concerned, and it must meet the electrical requirements of the detector.

- For non-IS devices, Crowcon recommends the use of steel wire armoured (SWA) cable. Suitable explosion-proof glands must be used.
- For IS devices, Crowcon recommends the use of twisted pair cable with overall screen and sheath. Suitable weatherproof glands must be used. IS devices must be used with a suitable Zener Barrier or Galvanic Isolator when used in a hazardous area.
- For fire detectors, Crowcon recommends the use of twisted-pair cable, screened with an overall protective sheath that is fireproof, for example, Pirelli FP200 or similar. Suitable weatherproof glands must be used. The maximum acceptable loop resistance is 100ohms.

Alternative cabling techniques, such as steel conduit, may be acceptable provided that appropriate standards are met.

The minimum acceptable supply voltage measured at the detector and the maximum current drawn by that detector is different for each device. Please refer to the relevant Installation, Operating and Maintenance Instructions provided with each detector to calculate the maximum cable distances allowed for different cable types. The maximum cable distance allowed is dependent upon the installation, for example, whether Zener Barriers or Galvanic Isolators are required (as for IS devices) or not.

When calculating the maximum cable length for a detector, take the minimum supply voltage at the Quad Channel Input Module as 18V at 350mA for a 3-wire detector head, 19.8V at 25.8mA for a 2-wire head. Typical cable characteristics are shown in Table 5.

Table 5: Cable characteristics

c.s.a (mm ²) <i>See note</i>	Typical Resistance per Km of Cable (Ohms)	Typical Loop Resistance per Km of Cable (Ohms)
0.5 (20)	39.0	78.0
1.0 (17)	18.1	36.2
1.5 (15)	12.1	24.2
2.5 (13)	8.0	16.0

Note: Approximate c.s.a. in awg given in brackets

Cable lengths should be calibrated according to the equations defined in the detector instructions sheet and the cable and Vortex characteristics specified above.

Vortex provides a number of internal and external earth terminals for safety earth and screen terminations. See Appendix F for further information on earthing.

Vortex has been tested and found to be compliant with EMC regulations using the following cable and gland configurations:

- SWA cable and SWA glands with electrical termination of the armour to the casing via the gland
- Screened cable with the screen terminated inside the casing via a metal tag attached to the gland, or terminated at the earth stud.
- Screened cable using an EMC gland where the screen is terminated to the enclosure via the gland. The Vortex standard enclosure contains cable entries with knockout plugs (18 at the top and 18 at the bottom). These can be fitted with a standard M20 cable gland.

3.7 Circuit Breaker

If the equipment is permanently connected to a mains supply then a circuit breaker must be included in the installation, in order to comply with the requirements of EN 61010-1 (Low Voltage Directive).

The circuit breaker must be close to Vortex and within easy reach of the operator. It must be marked as the disconnecting device for the Vortex.

The circuit breaker must comply with the relevant requirements of IEC 947-1 and IEC 947-3. The protective earth must not be disconnected even when the breaker is activated.

3.8 Zero adjustment and calibration of Vortex

3.8.1 General

Calibration must be carried out separately on the individual detectors and on associated Quad Channel Input Modules in the Vortex system. Calibrate the detector first, for the calibration procedure, please refer to the relevant Installation, Operating and Maintenance Instructions provided with the detector. Ensure at all times that local legislation and codes of practice are complied with.

Calibration gas and accessories are available from Crowcon. The instructions below use the Display Module. Ensure that you are familiar with the Display Module functionality (section 4.6) and the Channel Test Mode (section 7.4) before commencing.

If you are using VortexPC, the software has Zero and Calibration Wizards to enable you to carry out the calibration easily. For Vortex DIN, this is the only method. See VortexPC Help for details.

If you are calibrating a Quad Channel Input Module and detector for the first time, Crowcon recommends that two people are involved. One person should be at the detector and the other at the control panel. When gas is applied to the detector in the field the person at the control

panel can check that the detector is connected to the correct Quad Channel Input Module by observing the gas reading on the Display Module or on the connected PC.

3.8.2 Zero Adjustment and Calibration procedure

To adjust the zero and calibrate the Quad Channel Input Module for a channel using the Display Module buttons:

1. Inhibit the Quad Channel Input Module of the channel to be calibrated by pressing the appropriate ZONE INHIBIT button on the back of the Display Module. The calibration can be carried out without inhibiting the channel, but associated relays and audible and visual alarms may be triggered.
2. Ensure that the associated detector is reading zero level (4mA for a gas detector):
 - For an oxygen detector, the sensor must be disconnected from the current amplifier at the detector head. For intelligent oxygen detectors refer to the Installation, Operating and Maintenance Instructions supplied with the detector.
 - For other gas detectors, the detector should be in free mobile air.
 - For other 4-20mA devices ensure that the input is 4mA.
 - For a fire detector loop, disconnect the fire loop current connector at the Quad Channel Input Module.
3. Using the HOLD and STEP buttons, select the channel to adjust.
4. Once the display is held on the appropriate channel press the CHANNEL TEST button on the inside of the Display Module. The display should show GL for a gas detector or FL for a fire detector, and the detector level reading (this should be approximately zero).
5. Press the ZERO button. The display should read 0. If there is an E008 fault, it indicates that the incoming signal is too far from the nominal zero level to allow compensation. Check that the detector is wired correctly, the Quad Channel Input Module detector type switch setting is correct and that the detector input is 4mA or open circuit for a fire loop.
6. Provided that zero adjustment was successful, reconnect the sensor (for oxygen detectors only) or connector (for fire detectors only).
7. For an oxygen detector, expose the detector to free mobile air. Ensure that the display is showing GL and the current gas level reading. Allow this reading to stabilise. For other gas detectors, apply calibration gas to the detector (normally half scale, but must be greater than 20% of full scale). Ensure that the display is showing GL and the current gas level reading. Allow enough time for the detector to settle (typically two minutes).
For a fire detector, connect an ammeter into the channel circuit. Ensure that the display is showing FL and operate a manual call point. If the circuit has no manual call point, put a detector into alarm with a smoke canister.
8. Press the CAL button on the inside of the Display Module. The display shows the reading that Vortex believes the detector is sensing.
9. Use the – (HOLD) and + (STEP) buttons to adjust the Reading display to the correct reading:
 - For an oxygen detector in free mobile air calibrate to a reading of 20.9% Vol.
 - For other gas detectors, this should be the level for the applied calibration gas.
 - For other 4-20mA devices this should be the level for the applied condition.
 - For a fire detector, this should be the same reading as the ammeter in the circuit.

10. Press ACCEPT/RESET. The display should read the calibration gas concentration (for a gas detector) or the current in mA (for a fire detector). If there is an E009 fault, it indicates that the mA output from the detector and the required reading are too far apart to allow compensation. The detector calibration should be checked.
11. The detector and Quad Channel Input Module are now configured and calibrated correctly.
 - For a gas detector (other than oxygen), remove the calibration gas.
 - For a fire detector, remove the ammeter and reconnect the fire loop.
12. Press the RUN button on the front of the Display Module to release the Channel Test Mode.
13. Release any Inhibit Conditions by pressing the appropriate ZONE INHIBIT button.
14. If necessary select another channel and repeat this procedure until all channels are calibrated.

4 TECHNICAL INFORMATION: VORTEX

4.1 General

This section contains detailed technical information on the Vortex modules that you may need to refer to during installation, configuration or maintenance of the Vortex system. If you simply use Vortex for monitoring and responding to alarms, it is not necessary to read this chapter. See chapter 6, *Operation*.

4.2 Node Controller Module

4.2.1 Functions of the Node Controller Module

This module controls the operation of Vortex, gathering the channel readings from the Quad Channel Input Modules. After correcting them for the zero adjustment and calibration it calculates the detector levels and checks them against the alarm limits. Based on the corrected inputs, it drives the displays, calculates voted outputs and drives the Relay Output Modules. It also interprets the power and battery status. The Node Controller Module contains the configuration of the system, which is stored in non-volatile ferroelectric RAM (FRAM).

The Node Controller Module logs event data and controls communications between modules and communications with external devices using the Modbus protocol.

Figure 3 gives a general view of the Node Controller Module. Figure 17 (Appendix B) shows the electrical connections to the Node Controller Module.

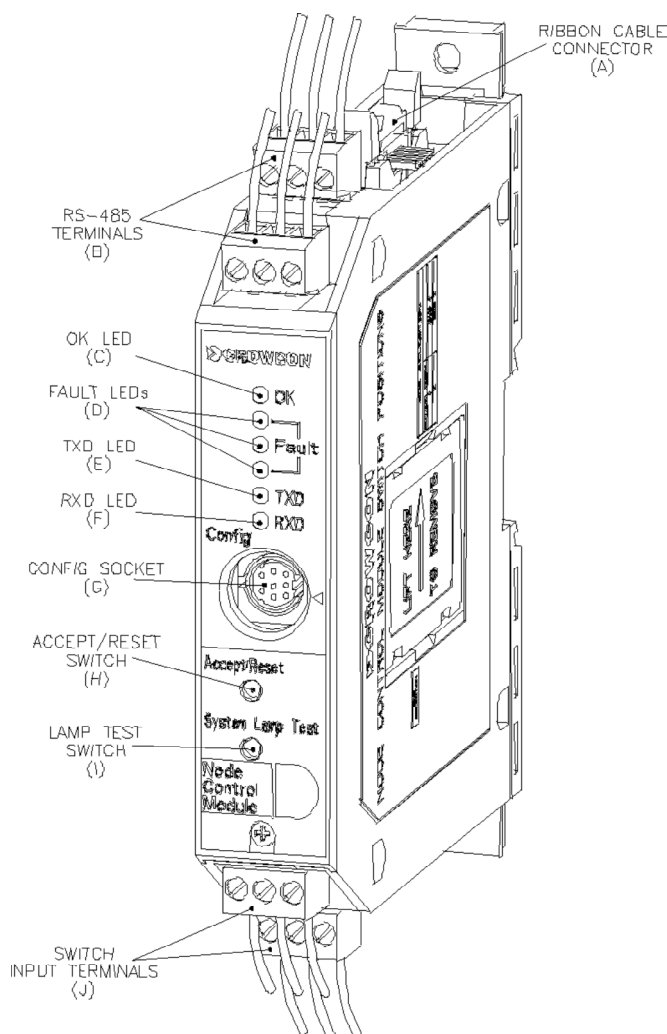

Figure 3: Node Controller Module

4.2.2 Node Controller Module indicators, switches and connectors

Table 6: Node Controller Module indicators, switches and connectors

Letters refer to labels in Figure 3.

Ribbon cable socket (A)	Provides connections to the Display Module (where fitted) and the Power Monitoring Module.
RS485 ports (B): see wiring diagram, Figure 17	These ports are intended for use by personal computers, programmable logic controllers and distributed control systems to allow remote monitoring of the system. It uses the Modbus RTU Slave protocol running at 9600 baud (address map available on application). There are two connectors to simplify "daisy-chaining" of multiple systems (up to 32 Vortex systems) which are electrically connected together. The Vortex at the end of a Modbus chain can use this second connector to attach a terminator (120 Ohm).
OK LED (C)	This LED flashes once per second to indicate normal operation

Fault LEDs (D)	These three LEDs are normally off. They indicate a code for system faults (see section 6.4.3). If more than one fault is present, the codes are lit in sequence.
TXD LED (E)	This LED is normally lit and flashes when the Node Controller Module sends data via the RS485 or RS232 connections.
RXD LED (F)	This LED is normally lit and flashes when data is received via the RS485 or RS232 connections. Internal sounder Provides audible warning of alarms and faults, confirmation of button presses, etc. It can be disabled using VortexPC.
Config socket (RS232 connector) (G)	This allows the connection of a personal computer for the use of VortexPC to configure the Vortex system. When a connector is inserted, the RS485 link is halted. Crowcon recommends that this port should not be used for routine monitoring.
Accept/Reset (H)	This switch has the same function as the ACCEPT/RESET button on the Display Module (see section 4.6).
System Lamp Test (I)	This switch has the same function as the LAMP TEST button on the Display Module (see section 4.6).
(J) see wiring diagram Figure 17	Accept Reset – Terminals 7 and 8 can be connected to cause an accept reset, see accept reset above. Lamp Test – Terminals 10 and 11 can be connected to cause a system lamp test, see system lamp test above. Hot Swap facility - Terminals 9 and 12 can be connected to allow other modules to be changed without generating errors. See section 7.7.

4.2.3 Configuring the Node Controller Module

There are no user-configurable settings on the Node Controller Module. The Bus Selection switch is always set to position 1.

The following system properties may be configured using VortexPC. Chose the System Configuration option on the Vortex menu.

Table 7: System Configuration Properties

Property	Configuration
System Name	16-character string used to identify the system
Enable Jump on Alarm	On/Off. If this option is set, the first channel that causes an alarm is automatically held on the display. The Hold LED flashes. The display remains held, even if other channels go into alarm, until the RUN button is pressed
Disable Local Buttons	Y/N. If Y then CAL, ZERO, PEAK HOLD CAL, CHANNEL TEST buttons have no effect
Disable Internal Sounder	Y/N. If Y, the internal sounder is disabled.

Modbus address	The Modbus address of the Vortex on the system. Usually 1 unless the system is multi-drop.
Number of Quad Channel Input Modules	1, 2 or 3
Number of Relay Output Modules	0, 1, 2, 3 or 4

4.3 The Bus Rail and electrical connections

The Vortex modules (apart from the Display Module and the power supply components) are mounted on a bus PCB, which acts as a motherboard providing the necessary power and communications to the modules, see Figure 4: Bus Rail Assembly Details. The bus PCB is inserted into a DIN Rail to create the Bus Rail assembly.

The Node Controller Module, Quad Channel Input Modules and Relay Output Modules have plugs that slot into sockets on the bus PCB, and clips to lock them on to the DIN Rail. Figure 1 shows how the modules are arranged on the Bus Rail assembly. For instructions for mounting the modules and removing them from the rail, see section 7.8.

The Bus Rail accepts DC power from the Power Monitoring Module through a 2-way cable attached to terminal JP1 on the bus. JP1 pin 1 is the positive connection.

Two Bus Rails can be connected together within the same cabinet, using the 10-way Bus Interconnection Ribbon Cable Assembly. Using two Bus Rails allows the maximum number of modules in one Vortex system to be fitted. The Vortex standard enclosure holds only one Bus Rail.

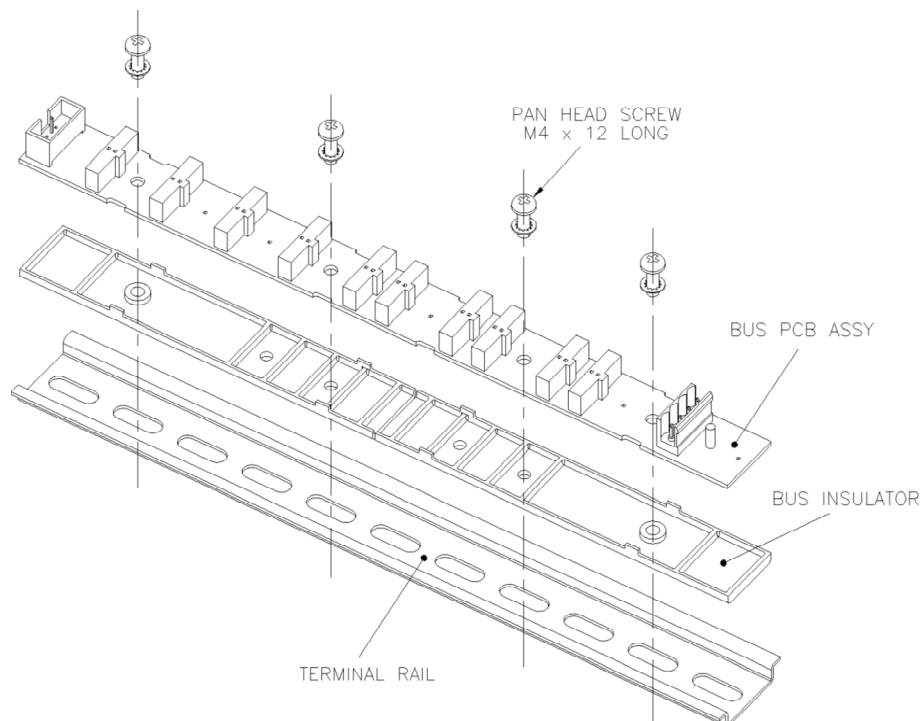

Figure 4: Bus Rail Assembly Details

4.4 Quad Channel Input Module

4.4.1 Functions of the Quad Channel Input Module

Each Quad Channel Input Module is used to power and monitor up to 4 detectors. For a list of available Crowcon detectors, see Appendix D.

The first channel on each Quad Channel Input Module can be connected to a gas detector, or to a maximum of 20 chained conventional loop-powered fire detectors and manual call points. The remaining channels can be used only with 4-20mA.

Figure 5 gives a general view of the Quad Channel Input Module. Figure 18 (Appendix B) shows the electrical connections between the Quad Channel Input Module and the detectors.

The detectors are connected to Inputs 1, 2, 3 and 4 labelled items A, B, C and D in Figure 5.

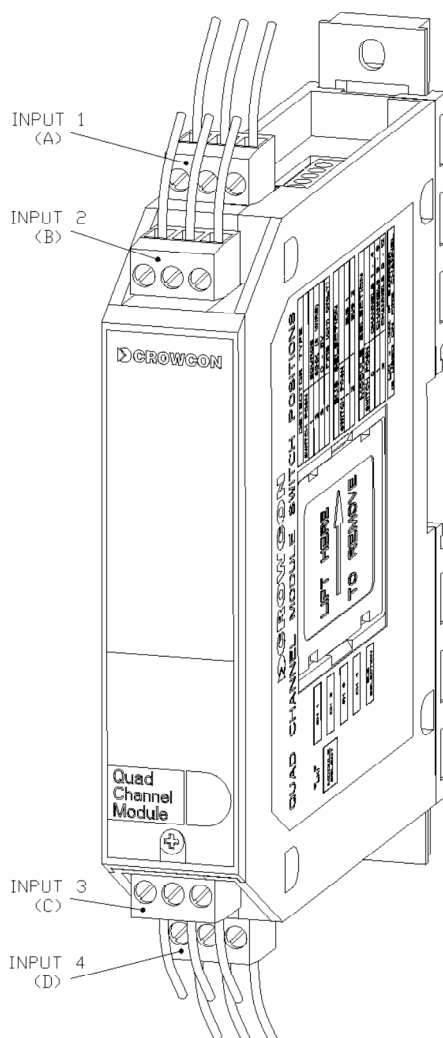

Figure 5: Quad Channel Input Module

4.4.2 Configuring the Quad Channel Input Module

The Quad Channel Input Module has switches for Detector Type, Selection and Module Selection, and a link LK11. See Figure 6

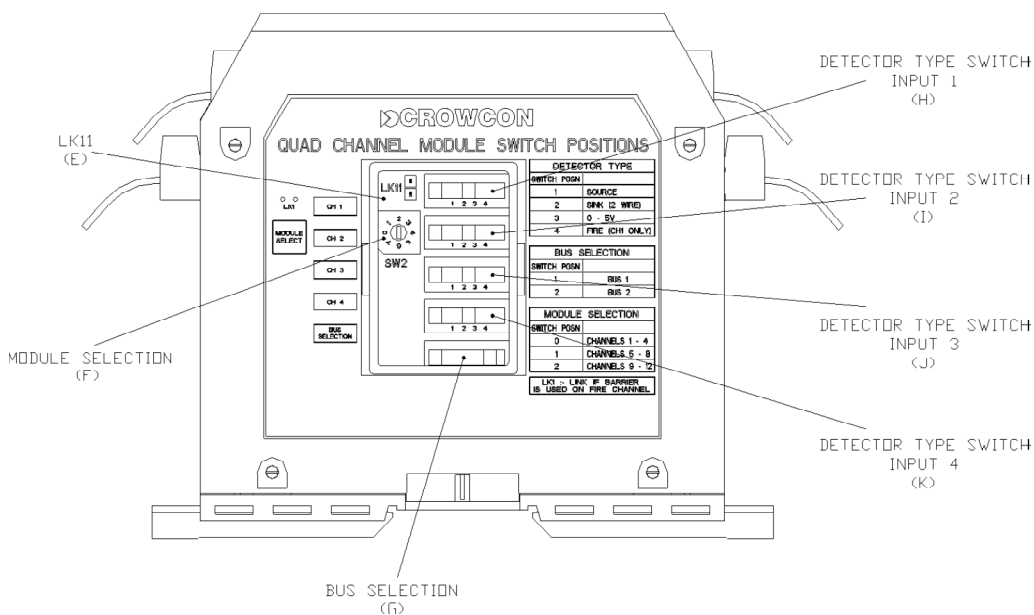

Figure 6: Switches on Quad Channel Input Module

If the system is supplied with Crowcon detectors, the Quad Channel Input Modules are already configured. If the system needs configuring, follow the instructions below.

Table 8: Quad Channel Input Module switch settings

Letters refer to labels in Figure 6.

<p>LK 11 (E)</p>	<p>If the first channel of a module is a fire detector connected to the Vortex system via a Zener Barrier, then make the link LK11. In all other cases, including when the fire detectors are connected directly to the panel, leave this link unmade.</p>
<p>Module Selection Switch (F)</p>	<p>Determines the channel number for the module. The physical order of the modules on the Bus Rail is not important.</p> <p>Position 0 - This module has channels 1-4</p> <p>Position 1 - This module has channels 5-8 if two or three modules are used</p> <p>Position 2 - This module has channels 9-12 if three modules are used</p>

Bus Selection Switch (G)	Always set to position 1.
Detector Type Switch input 1 to 4 (H, I, J and K).	Selects the Detector Type. Position 1 - 3-wire, 4-20mA source detector Position 2 - 2-wire, 4-20Ma 3-wire, 4-20mA sink detector Position 3 - 2-wire, 0-5V Position 4 - Fire (Channel 1 of module only)

Each detector channel is configured using VortexPC. Choose the Inputs Configuration option on the Vortex menu. Select the appropriate channel to view its current configuration. See Table 9.

These properties apply to all channels regardless of their Detector Type (except Enabled, which is not available for channels set as Not Configured detectors).

Table 9: Detector channel configurable properties

Property	Configuration
Channels	
Identity	An 8-character string used to identify the channel
Detector Type Gas	Fire (Channel 1 of module only) Not Configured if channel has no detector
Enabled	On/Off. A detector must be enabled and configured to participate in the system. If there are no participating detectors, an E002 error is generated. A channel may be removed from the system using this option even if it is configured, for example, a faulty detector.
Gas detectors	
Units	Selects the units for Gas Detectors: %LEL, %VOL, ppm or no units
Range	For %LEL and %VOL the range can be 0 to 1, 2, 2.5, 5, 10, 20, 25, 50 or 100. For ppm the range can be 0 to 1, 2, 2.5, 5, 10, 20, 25, 50, 100, 200, 250, 500, 1000, 2000, 2500, 5000, 10000. For the 10000 range, the maximum display is 9990.

Property	Configuration
Out of range values - Interpret High and Interpret Low.	<p>Each option can be set to Info, Inhibit or Fault. They specify how the system should respond to values that are under-range and over-range, respectively. The low region is 1 to 3 mA and the high region are 21.5-24.5 mA.</p> <p>Info If Interpret High is set to Info, the display shows “Hi” and the nominal gas level is treated as full scale. If Interpret Low is set to Info, the display shows “Lo” and the nominal gas level is treated as zero. No fault is indicated. The Hi and Lo flags can be used for voting in the relay logic.</p> <p>Inhibit If Interpret High is set to Inhibit, the display shows “In” and the nominal gas level is treated as full scale. If Interpret Low is set to Inhibit, the display shows “In” and the nominal gas level is treated as zero. The Inhibit signal for this channel can be used for voting in the relay logic.</p> <p>Fault If either region is set to Fault then the under-range or over-range fault is generated for the channel. This is intended to catch short-circuit faults (High) and open-circuit faults (Low).</p>
Alarm Levels 1, 2 and 3	<p>The alarm thresholds must be set within the range for the detector, using the units specified. The alarm level must be set to either Rising or Falling. The resolution of the Alarm Levels is the same as that of the Vortex system. It is not necessary for Alarm 1 to be the lowest and Alarm 3 to be the highest. Alarm 3 is not indicated and does not cause the sounder to operate</p>
Zero Suppression	<p>On/Off. The default is On. When this option is selected, the readings less than 3% of full scale are suppressed to zero.</p>
Fire detectors	
Current thresholds	<p>The current thresholds must be set within the range 0 to 60mA, in the order Open Circuit < Fire < Short Circuit</p>
Reset Time	<p>Between 0 and 255 seconds. The time that the loop current is removed to reset a latched fire detector on pressing ACCEPT/RESET after a fire alarm.</p>
Stabilisation Time	<p>Between 0 and 255 seconds. The time allowed for the fire detector to stabilise after a reset before coming on line.</p>

4.5 Relay Output Module

4.5.1 Functions of the Relay Output Module

Optional Relay Output Modules may be fitted to the system and programmed to provide voted channel and system events. These relays are controlled by the Node Controller Module.

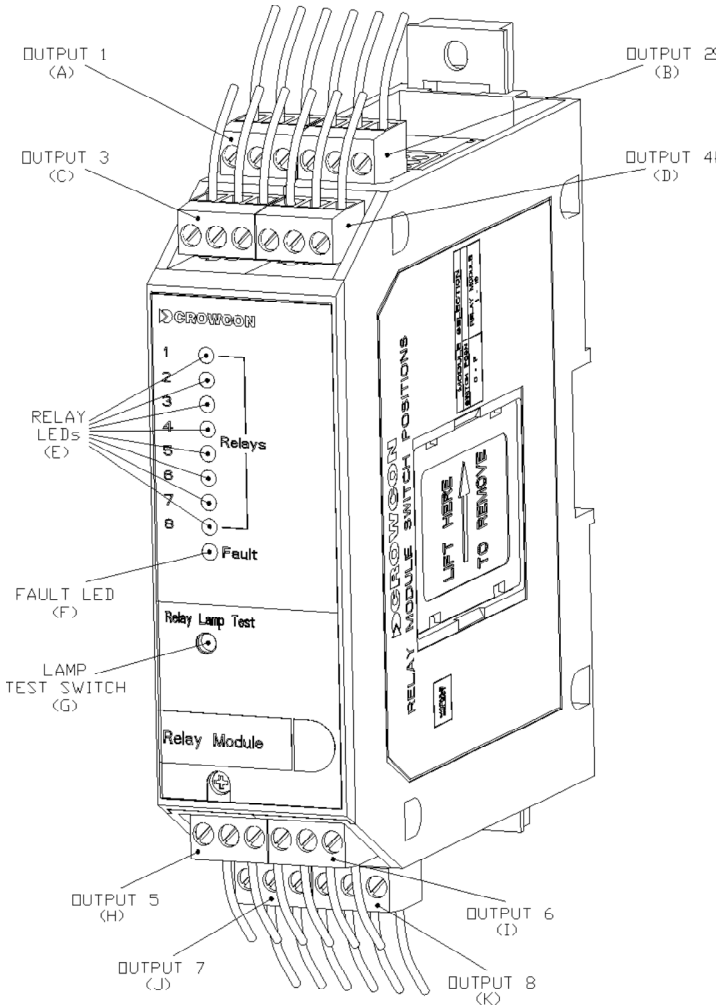

Figure 7: Relay Output Module

Table 10: Features of the Relay Output Module

Letters refer to the labels in Figure 7.

Relays	8 Single-Pole-Change-Over (SPCO) relays rated at 6A 250Vac. These relays are configurable separately for channel, alarm, voting, time delays and relay type. Configuration is done through the VortexPC software.
Relay Outputs (A to D and H to K)	Connection to each relay 1 to 8. Normally open, normally closed and common connections are defined in appendix B Figure 19
Yellow LED for each relay (E)	Indicates the relay status (LED on = energised, LED off = de-energised). The relay coils are continuously monitored in both energised and deenergised states.
Fault LED (F)	Indicates a fault condition. This is also shown on the Node Controller Module LED and the Display Module System Fault LED (if fitted). This LED also indicates when a relay module is unconfigured e.g. at power up the Led in on until the node controller has sent the relay configuration to the relay module.
Relay Lamp Test switch (G)	When pressed, checks that all the LEDs on the Relay Output Module are functioning

4.5.2 Configuring the Relay Output Module

The physical order of the modules on the Bus Rail is not important, but, in order to reduce interference with the input channels when switching heavy loads, we advise you to place Relay Output Modules at the right-hand end of the DIN Rail.

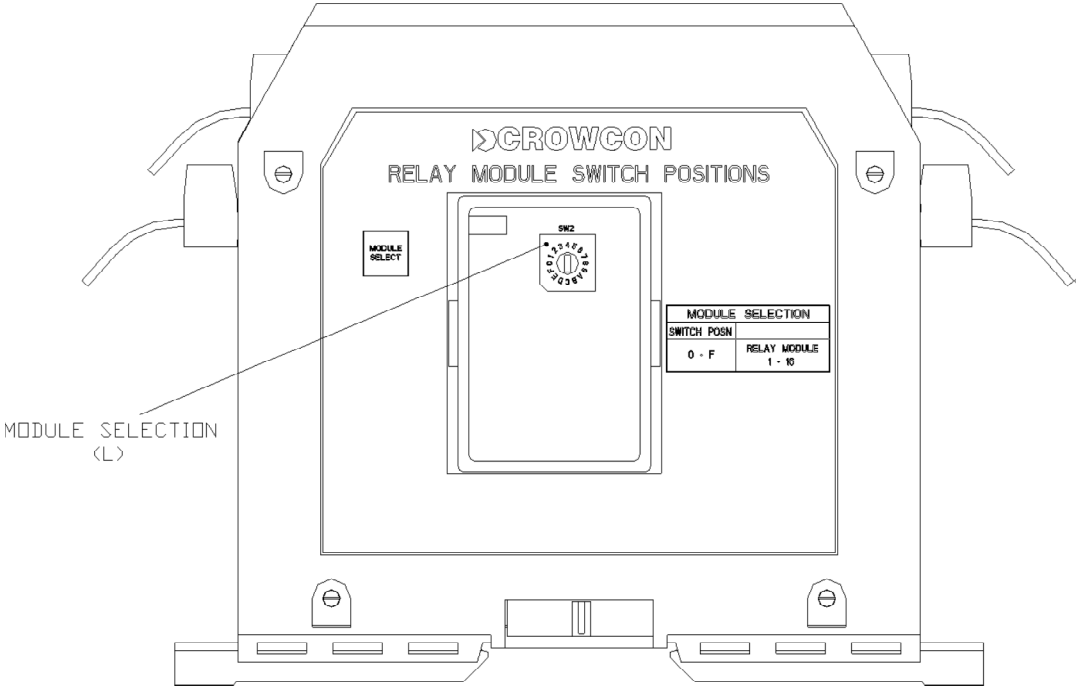

Figure 8: Relay Output Module Selection Switch

Table 11: Relay Output Module switch settings

The letters refer to labels in Figure 8

<p>Module Selection Switch (L)</p>	<p>Determines whether the relays on the module are configured as relays 1-8, 9-16, 17-24 or 25-32..</p> <p>Position 0 - This module has relays 1-8</p> <p>Position 1 - This module has relays 9-16 if two, three or four modules are used</p> <p>Position 2 - This module has relays 17-24 if three or four modules are used</p> <p>Position 3 - This module has relays 25-32 if four modules are used</p>
------------------------------------	--

Relay Output Modules are configured in VortexPC, using the Outputs Configuration option on the Vortex menu. Select the appropriate relay to view its current configuration. The configurable properties of relays are listed in Table 12.

Table 12: Relay configurable properties

Property	Configuration
Identity	An 8-character string used to identify the Relay Output.
Enabled	On/Off. A relay must be enabled and configured to participate Relays may be removed from the system by clearing this check box. This is recommended only when the relay is temporarily removed, not as a long-term solution.
Output Type	Latching, Non-Latching, Latching Acceptable, Non-Latching Acceptable, Pulsed, Reset Pulse or Not Configured. See Table 13. Any unused relays should be set to Not Configured.
On Delay Time	The waiting period before the relay is activated. Where applicable, 0 to 65535 seconds.
Off Delay Time	The waiting period before the relay is deactivated, except for Pulsed and Reset Pulsed, where it is the period for which is relay is activated. Where applicable, 0 to 65535 seconds.
Energisation	Either Normally Energised or Normally De-Energised The default is Normally De-Energised.

Table 13: Relay output types

Note that in the diagrams below, for all output types other than Pulsed and Reset Pulse, the On and Off Delay times are presumed to be zero.

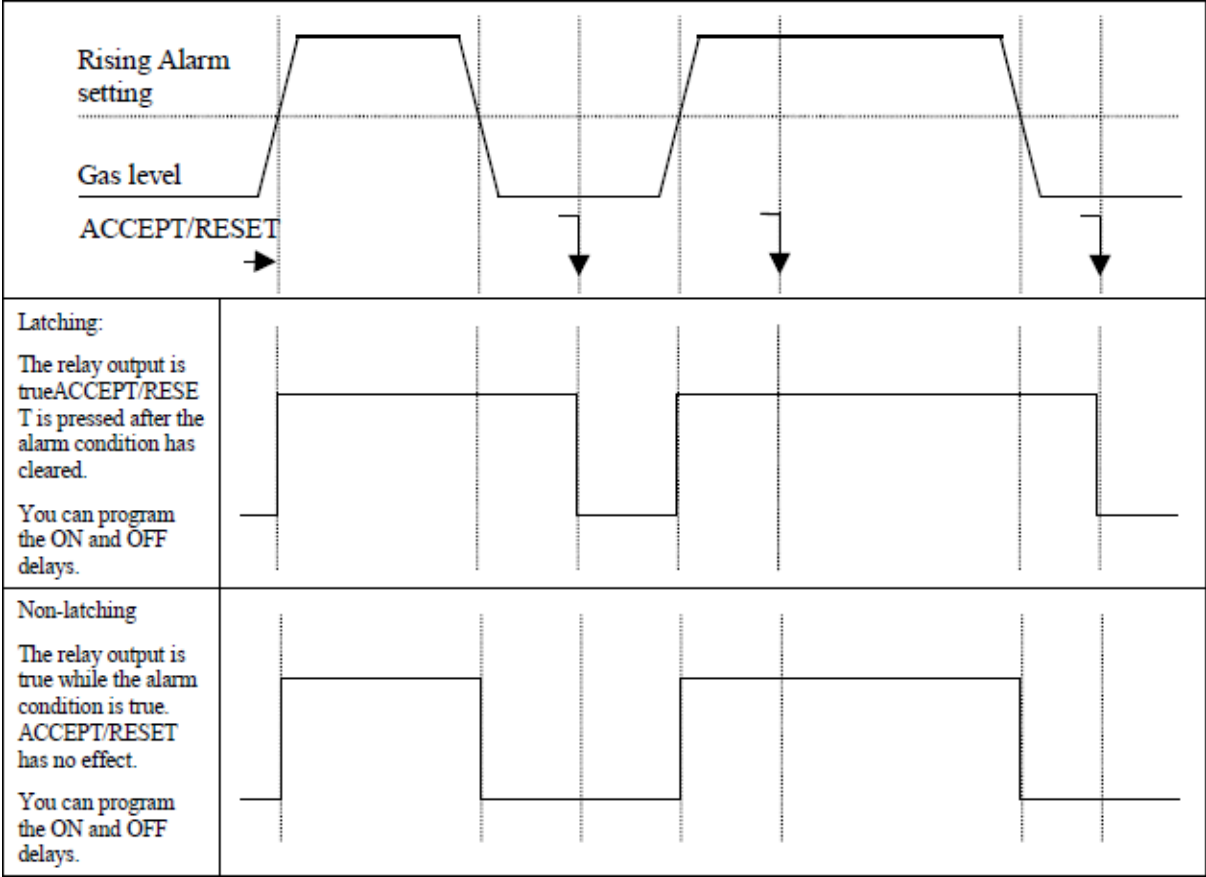

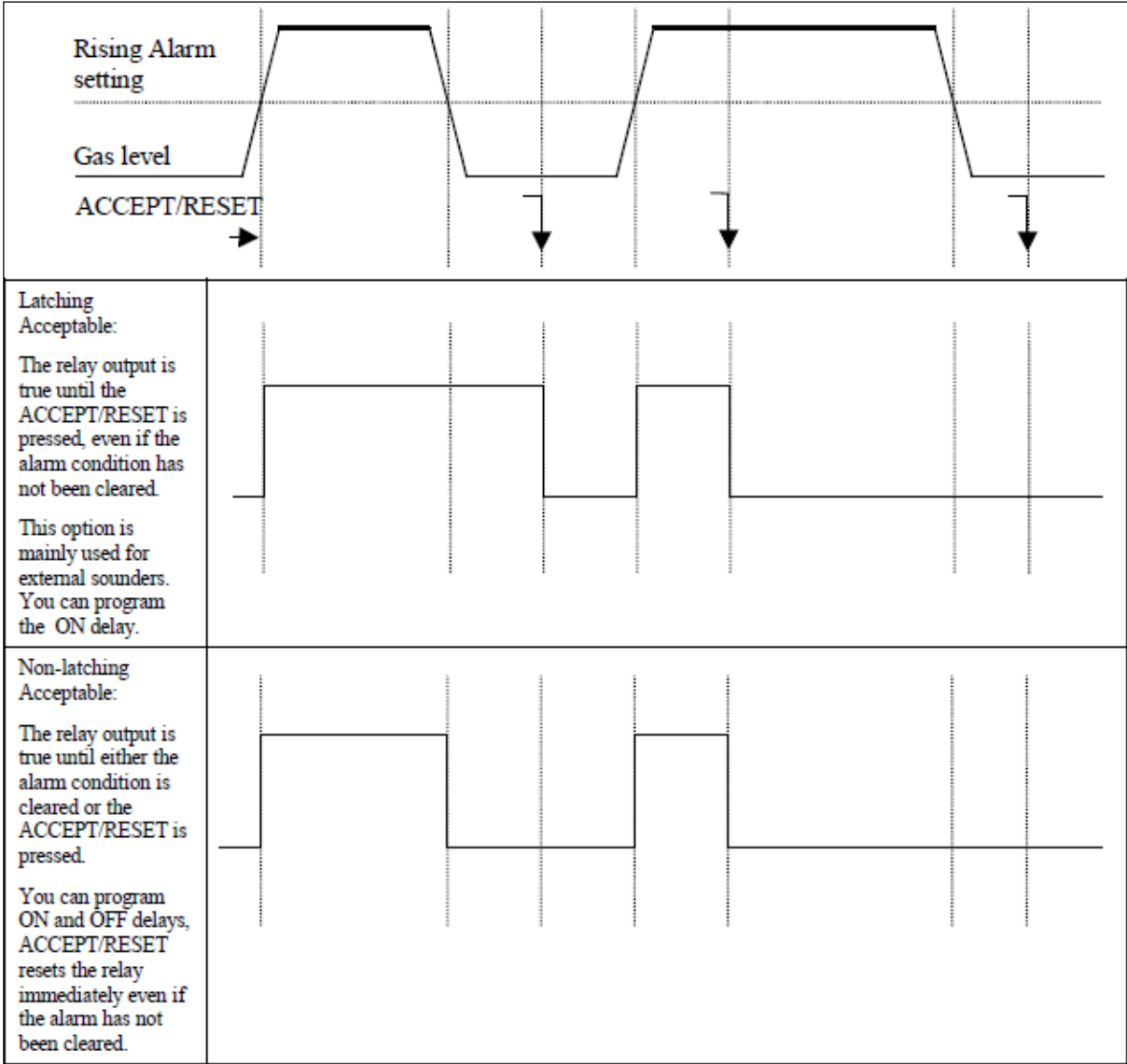

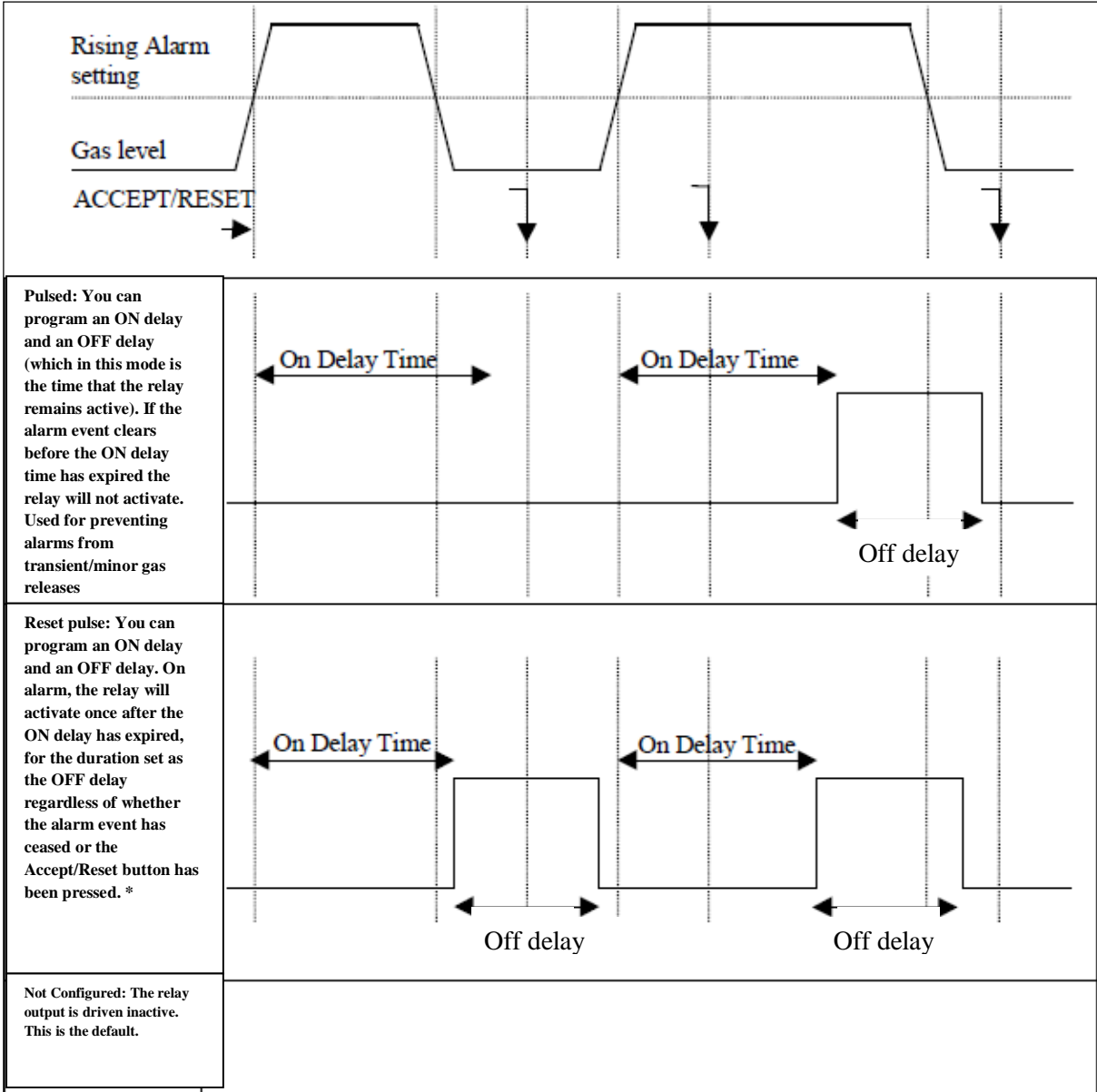

*Note: The Reset Pulse relay function is typically used for automatic reset of latched alarms by connecting relay contacts to the 'Remote Accept/Reset' terminals on the Node Controller.

4.5.3 Configuring the Relay Logic

The relay logic links detectors to relay outputs and is configured using the Relay Logic option in VortexPC. Relay Logic cannot be configured for relays whose relay type is Not Configured, channels with detector type as Not Configured cannot be used. You should configure all the Quad Channel Input Modules and Relay Output Modules as required before the Relay Logic.

Table 14: Relay Logic configurable properties

Property	Configuration
Detector link event (8 per detector)	Each detector link event can be one of seven events: Alarm 1, Alarm 2, Alarm 3, Inhibit, Fault, High Information, Low Information (when configured as such for the High and Low regions of a 4-20mA detector)
System links (8 for system fault and 8 for system sounder)	The system fault event and system sounder event can be linked to a relay Relay Vote count The Vote Count for the relay, this is the number of the specified events (detector events and system events) that must occur to trigger the relay. For example, if three detector events have been selected for the relay, a vote count of 1 means that any of the events will trigger the relay.

Fire detectors will generate Alarms 1, 2, and 3 on a fire event.

In Vortex PC, for each relay, select the detector(s) and the corresponding events, or system properties to trigger the relay.

4.6 The Display Module

4.6.1 Functions of the Display Module

Vortex, Vortex Rack and Vortex Panel include a Display Module that in normal operation provides a display of detector input and reports the current status of the system. It also provides local user control of the system through a set of push-buttons, seven at the back and five on the front. See Figure 9 and Figure 10.

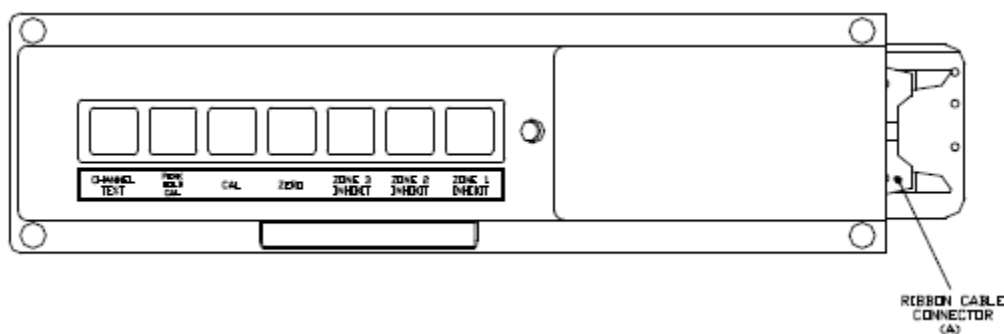
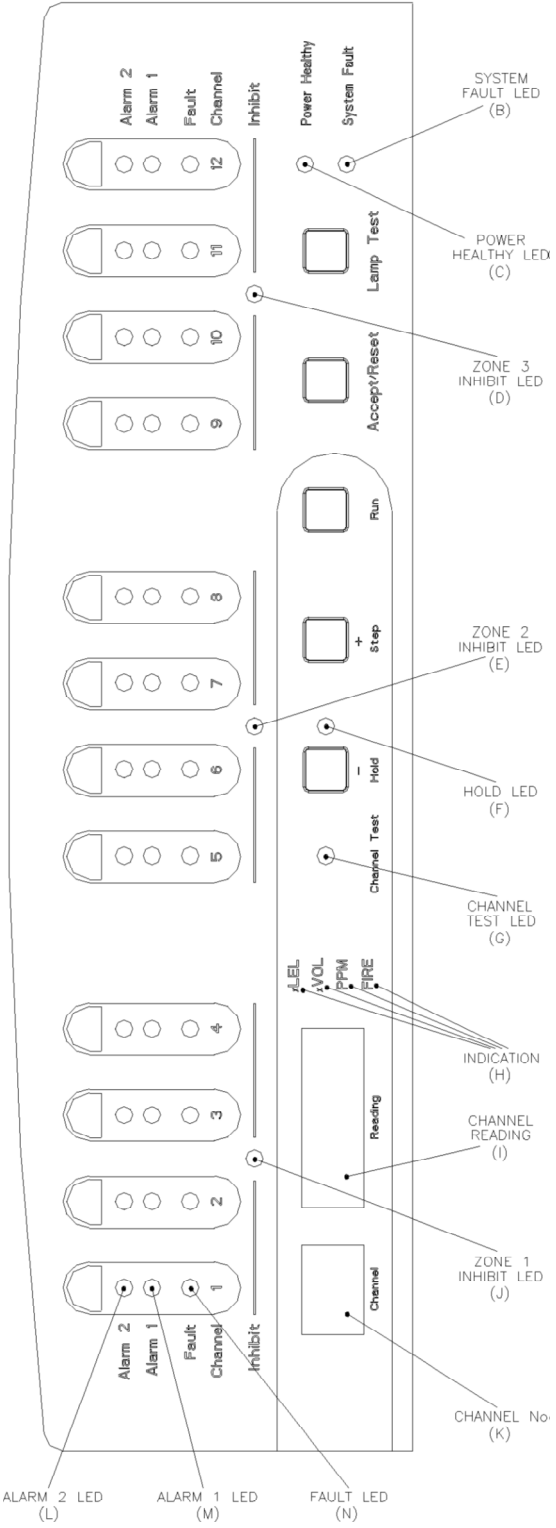

Figure 9: Back of Display Module



The Display Module shown is for Vortex (in its standard enclosure), Vortex Rack and Vortex panel have only minor differences in outline.

Figure 10: Front of Display Module

In Vortex and Vortex Panel the Display Module is mounted on the enclosure door. In Vortex Rack, the Display Module is mounted on a 19"rack panel. For Vortex DIN there is no Display Module and monitoring can be done using the RS485 port on the Node Controller Module (see section 4.2)

The Display Module displays the status of each channel. If any alarm or fault condition is detected, the relevant LED lights up on the Display Module. Depending on the configuration of the system, the internal sounder on the Node Controller Module emits a sound, and any assigned relays operate.

Details of the displays module features can be found below. The type of input monitored on each channel may be indicated on the front of the Display Module by a label above the LEDs for that channel.

4.6.2 Display Module Features

Table 15: Display module features

The letters in parentheses refer to Figure 9 and Figure 10.

Feature	Description
Ribbon Cable connector (A)	This connector accepts the ribbon cable to connect the display to the node controller module.
System Fault.LED (B)	Yellow LED indicates a detected system fault. The specific fault is indicated on the Node Controller module LEDs; see section 6.4.3.
Power Healthy LED (C)	This LED provides information about the status of the various power systems. For the code, see section 6.4.2.
Zone Inhibit LEDs (D, E, and J)	Yellow LED for each zone (set of channels on a Quad Channel Input Module). Indicates that the zone, or a channel in the zone, is currently inhibited.
Hold LED (F)	The green LED when continuously illuminated indicates that the HOLD button has been used to hold the current channel. When this LED flashes, it indicates "Jump on Alarm". The Channel Reading now shows the channel (or the first of more than one channel) that has gone into alarm.
Channel Test LED (G)	The yellow LED when flashing indicates that the system is in Channel Test mode (section 7.4).
Units Indication LEDs (H)	Indicates what the units of the currently displayed reading are.
Reading (I)	The reading on the channel currently indicated by the Channel display. The number is shown in red on a 7-segment display. This should be read in conjunction with the units indication. For the use of this display in Channel Test mode, see section 7.4.
Channel Number (K)	A green 7-segment display that normally displays the number of the currently-displayed channel (The other channels are continuously monitored regardless of this display.) For the use of this display in Channel Test mode, see section 7.4.

Feature	Description
Channel Alarm 1 and Alarm 2 LEDs (L and M)	Red LEDs for each channel. Illuminated when the alarm level is reached on the channel. When the alarm is first raised, the LED flashes. After the ACCEPT/RESET button is pressed, the LED goes out if the alarm condition has been cleared. If the alarm condition still exists, it displays continuously.
Channel Fault LEDs (N)	Yellow LED for each channel. Illuminated when a fault is detected on the channel. When the fault is first raised, the LED flashes. After the ACCEPT/RESET button is pressed, the LED goes out if the fault has been cleared. If the fault still exists, it displays continuously.
HOLD (-) Button	On front of module. Press to hold the display on the current channel. Also used to decrease the Reading display in Channel Test mode (section 7.4).
STEP (+) Button	On front of module. Press to step the display to the next channel. Operates only when HOLD has been selected. Also used to increase the Reading display in Channel Test mode (section 7.4).
RUN Button	On front of module. Press either to restart cycling through the channels after HOLD has been selected, or to end Channel Test mode.
ACCEPT/RESET Button	On front of module. Press to inform Vortex that you have noted that an alarm or fault condition has occurred. Pressing this button silences the internal sounder. If the alarm condition has cleared, it clears any red or yellow LEDs in the channel status display
LAMP TEST Button	On front of module. Press to test all the LEDs on the Display Module and Node Controller Module. See section 7.5.
CHANNEL TEST Button	On rear of module. After the HOLD button has been used to select a channel, use the Channel Test button to display alarm levels (section 7.4) or for zero adjustment and calibration (sections 3.8 and 7.3). This button can be disabled using VortexPC.
PEAK HOLD CAL Button	On rear of module. Used for the Peak Hold Calibration (section 7.3). Can be disabled using VortexPC.
CAL Button	On rear of module. Used for the Calibration (section 3.8 and section 7.3). Can be disabled using VortexPC.
ZERO Button	On rear of module. Used for the Zero Adjustment (sections 3.8 and 7.3). Can be disabled using VortexPC.
ZONE INHIBIT Buttons	On rear of module, one button for each zone. Used to prevent the corresponding output relays from being activated during testing or calibration (sections 3.8, 7.3 and 7.4). VortexPC can be used to inhibit individual channels. Note: Even in the inhibit condition, the alarm LEDs on the display module are triggered if alarms occur.

4.7 Power Monitoring Module

4.7.1 Functions of the Power Monitoring Module

The Power Monitoring Module is shown in Figure 11. The Power Monitoring Module is a standard part of the Vortex system.

Note: for multiple Vortex Rack, Vortex panel and Vortex DIN systems supplied by Crowcon, the Power Monitoring Module may have been replaced by a single Power Management System, which meets the EMC and Low Voltage Directive requirements.

If the backup batteries are fitted and the main ac power supply is lost, the system automatically switches over to the standby battery operation. If loss of power continues, the battery is disconnected from the system to prevent it from being over-discharged and permanently damaged.

The main features of the Power Monitoring Module are listed in Table 16.

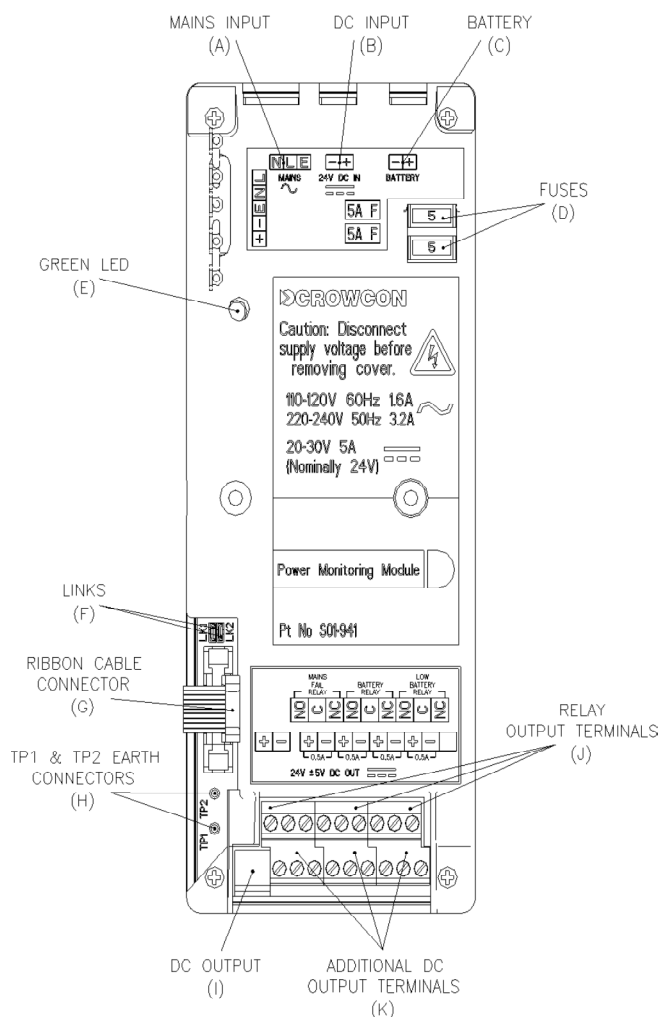

Figure 11: Power Monitoring Module

Table 16: Features of the Power Monitoring Module

Letters refer to labels in Figure 11.

Mains (connector) (A)	Input from mains supply, when the optional Power Supply Unit is fitted. This is rated at 29.5V, 150W, with input at 110-120V or 220 to 230Vac (switched), 50-60Hz.
24Vdc In (connector) (B)	If a 24Vdc external power source is specified, then the Mains Power Supply Unit is not fitted. A 20-30Vdc supply fused at 5A must be provided. The Power Monitoring Module includes 24V filtering. You must ensure that the 24Vdc is suitable for use with Vortex. If internal batteries are expected to be charged from an external DC supply then the supply should have a minimum voltage of 29.0V
Battery (connector) (C)	Connection to backup batteries. See section 4.7.4.
5A F (two fuses) (D)	The lower fuse is connected to the batteries (if fitted) and the upper fuse is connected to the dc output of the mains power supply and the 24V dc input (item B).
Green LED (E)	This indicates that there is DC input to the power monitor board, either from the mains power supply unit or from the DC input (item B)
LK1 and LK2 (links) (F)	LK1 must be fitted if the system does not have standby batteries fitted. If neither the link nor the batteries are fitted then a Power Status Fault will always be present. If the system is to be powered up without an external power supply, LK2 can be shorted to enable the system to power up from fully-charged batteries.
Ribbon cable connector (G)	This connects to the Node Controller Module (section 4.2) and the Display Module (if fitted).
TP1 and TP2 Earth links (H)	When Vortex is supplied in the standard enclosure, it is supplied with the enclosure isolated from 0V and the earth link fitted to TP2. This link is required for systems where the 0V is isolated from the enclosure. If the system requires the 0V to be connected to the enclosure, move the link wire to TP1. See Appendix F for further details of earthing. DC Output This is the output from the power monitor module for connecting to the bus assembly see section 4.3

DC/Mains Fail relay output (J leftmost set of 3 connections)	This indicates the status of the dc input to the Power Monitoring Module. This input comes either from a mains Power Supply Unit or from the 24Vdc In terminals. The relay is normally energised and deenergises when the dc input is absent.
Battery (Disconnect) relay output (J centre set of 3 connections)	Batteries have to be protected against deep discharge, as it causes permanent damage that eventually shortens battery life. If the battery terminal voltage falls below about 20V, this relay trips out. It disconnects the battery power to the rest of the Vortex system. It is normally energised until the voltage goes below the threshold, and does not reconnect until the battery terminal voltage is recharged to about 26V.
Low Battery relay output (J rightmost set of 3 connections)	This relay indicates when the battery terminal voltage falls below about 22V, which shows that the battery is approaching the exhaustion of its charge capacity. It is normally energised until the voltage goes below the threshold, and does not reconnect until the battery terminal voltage is recharged to about 26V.
24Vdc Out (connectors) (K)	There are four 500mA electronically-fused outputs that can be used to power auxiliary equipment and can be used in conjunction with the relay modules to drive audible/visual alarms. These outputs are 19-29V dependent on the dc input, with a 0.6-0.7V drop. Typically, this is 28.5V.

4.7.2 Removing the 5-Way Cable Assembly

With the Power Monitor Module isolated from the system remove the 4 screws from each corner of the Power Monitor Module cover and remove the cover from the PCB. Disconnect the 5 way cable header from PCB. Re-assemble the Power Monitor Module PCB into the cover.

4.7.3 Mounting the Power Monitoring Module on a DIN Rail

The Power Monitoring Module can be mounted on a DIN Rail using the adapter plate and clips provided, this is not applicable in Vortex. Screw the adapter plate to the clips in the required orientation. Then screw the Power Monitoring Module to the adapter plate, see Figure 12. Push the clips on to the DIN Rail until they click home.

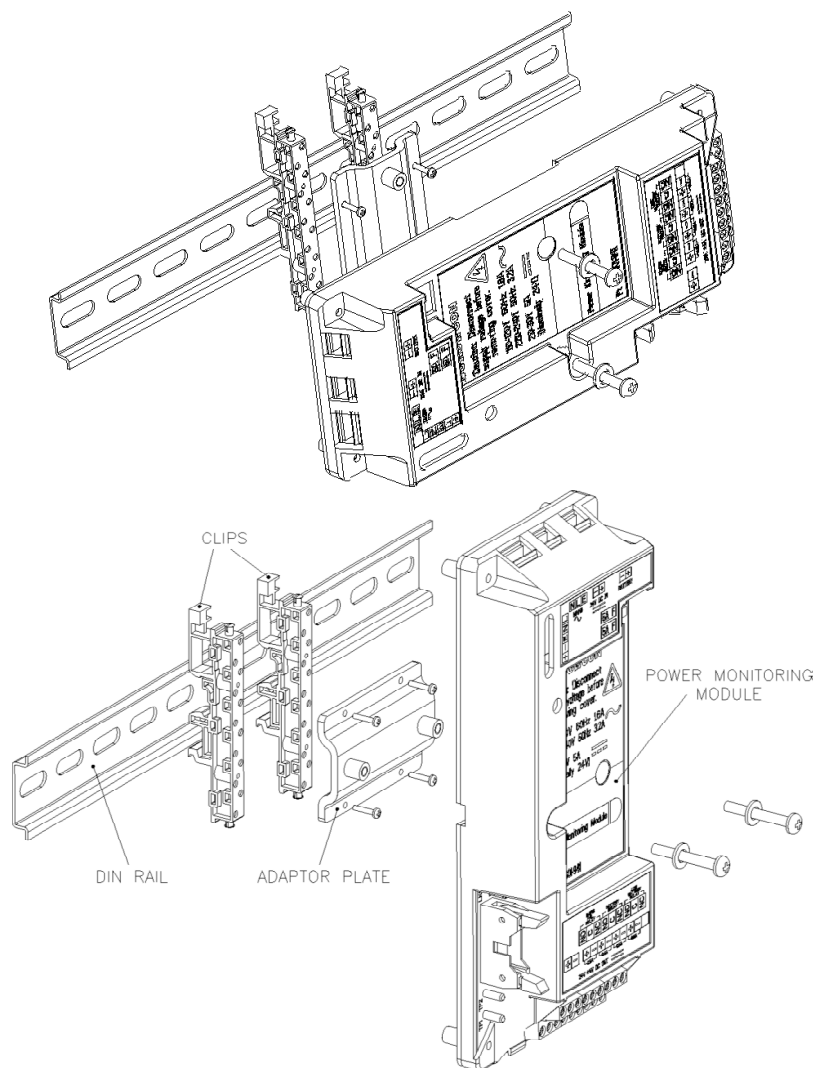

Figure 12: Alternative mountings for the Power Monitoring Module

4.7.4 Backup batteries

The Power Monitoring Module is capable of charging and monitoring two 12V, 2Ah at 0.25A, sealed lead-acid batteries connected in series to provide 24V dc. If the main ac power supply is lost, the system automatically switches over to the standby battery operation, this is indicated on the Power Status LED on the Display Module. If loss of power continues, the battery is disconnected from the system to prevent it from being over-discharged and permanently damaged.

In the Vortex standard enclosure these batteries are mounted behind the Power Monitoring Module. There is a 10A in-line fuse between the two batteries behind the Power Monitoring Module. For instructions on changing these batteries, see section 7.9.

Larger batteries or external backup power supply systems may be supplied and fitted according to requirements, details of these are beyond the scope of this manual. See the Specification Sheet supplied with the system for more information.

NOTE Where external DC supplies are used, they should be connected via the DC input connection **NOT** the battery input.

4.7.5 Power Failure

Under total power failure all system configuration data is protected by non-volatile Ferroelectric RAM (FRAM) in the Node Controller Module. Logged data is not protected and is lost.

The power status is displayed by the Power Healthy LED on the Display Module, where fitted.

Detectors have a warm-up time when power is initially connected or reconnected after a power loss. During this period, detector signals may not be reliable.

5 TECHNICAL INFORMATION: FIELD DEVICES

5.1 General

This chapter contains detailed technical information on the use of field devices (detectors and audible and visible alarms) with Vortex. You may need to refer to this during installation, configuration or maintenance of the Vortex system.

If you simply use Vortex for monitoring and responding to alarms, it is not necessary to read this chapter. See chapter 6, *Operation*.

5.2 Gas Detectors

5.2.1 Gas detector location

There are no rules that dictate the siting and location of detectors. However, considerable guidance is available from:

- BS EN 50073:1999, Guide for Selection, Use and Maintenance of Apparatus for the Detection and Measurement of Combustible Gases or Oxygen.

Similar codes of practice of other countries may be used where applicable. In addition, certain regulatory bodies publish specifications giving minimum gas detection requirements for specific applications.

The detector should be mounted where the gas is most likely to be present. The following points should be noted when locating gas detectors:

- To detect gases that are lighter than air, for example, methane, detectors should be mounted at high level. Crowcon recommends the use of a Collector Cone.
- To detect gases that are heavier than air, for example, butane, detectors should be mounted at low level. Contact Crowcon for details.
- To detect gases with similar weight to air, for example, hydrogen sulphide, mount the detector at normal breathing height.

- Mounting of oxygen detectors requires knowledge of the gas displacing the oxygen. For example, carbon dioxide is heavier than air and displaces oxygen at a low height. Under these circumstances oxygen detectors should be placed near ground level.
- When locating detectors, consider the possible damage caused by natural events such as rain or flooding. For detectors mounted outdoors, Crowcon recommends the use of weatherproof caps or spray deflectors.
- Consider ease of access for functional testing and servicing.
- Consider how the escaping gas may behave due to natural or forced air currents. Mount detectors in ventilation ducts if appropriate.
- Consider the process conditions. Gases that are normally heavier than air, but are released from a process line that is at a high temperature and/or under pressure, may rise rather than fall.

The placement of the sensors should be decided following the advice of experts with specialist knowledge of gas dispersion, experts with knowledge of the process plant system and equipment involved, and safety and engineering personnel. **The agreement reached on the locations of sensors should be recorded.**

5.3 Fire detectors

Only one fire loop may be fitted to each Quad Channel Input Module, and this can only be connected to the first input channel. Up to 20 detectors, for example, Apollo Series 65 or Orbis, may be used on the same loop at any time. The fire loop can also support other switched devices such as manual call points.

Devices on the loop may be mixed provided electrical characteristics are compatible and fire regulations allow.

All fire loops require a 1.8Kohm end-of-line resistor to be fitted (R_t in Figure 13). Simple switch devices such as manual call points require a 470ohm series resistor (R_m in Figure 13). A fire detector circuit can be represented by an equivalent circuit of a switch operating in series with a sensor resistor (R_s in Figure 13).

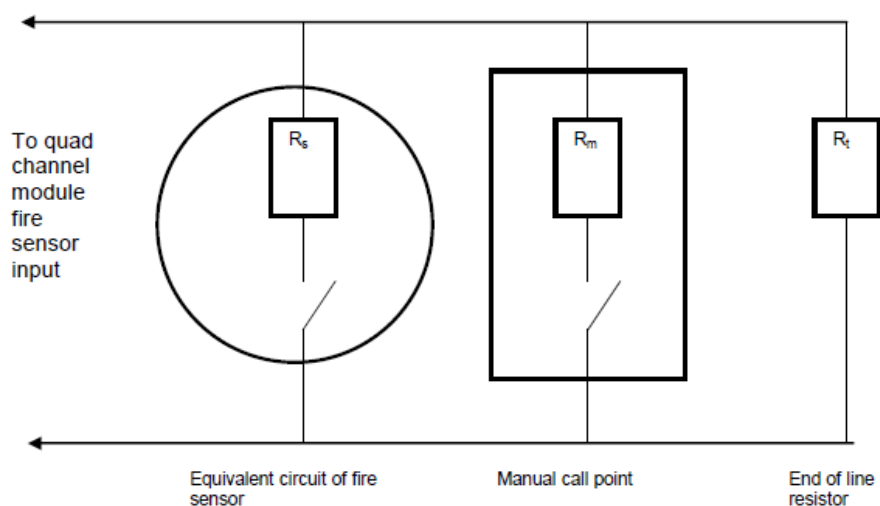

Figure 13: Representation of a fire detection circuit

With no detectors in alarm (all switches open) a small current flows in the circuit through the end-of line resistor (R_t). If a short circuit or open circuit cable fault occurs, the current in the loop increases or decreases. The Quad Channel Input Module detects this and a fault alarm is raised.

If a fire is detected (either the fire detector switch closes or the call point is activated), the current flowing in the loop changes and the Quad Channel Input Module detects this and a fire alarm is raised.

Figure 18 in Appendix B shows the electrical connections to be made to the Quad Channel Input Module. For essential information about earthing, see Appendix F.

5.3.1 Fire detector location

It is beyond the scope of this manual to describe the rules and regulations governing the installation of fire detection equipment. Assistance and guidance should be sought from the governing body in the country concerned before fire detection equipment is installed.

Further advice is available from Crowcon if required.

5.4 Connections for audible/visual alarms

Vortex is able to drive audible and visual alarms via any relay outputs. Any 20 – 29.5V dc field device (to a maximum of 500mA) may be powered by the dedicated dc outputs on the Power Monitoring Module.

For essential information about earthing, see Appendix F. For further assistance, please contact Crowcon.

6 OPERATION

6.1 General

This section describes the use of the Vortex system for monitoring, and the display of faults and alarms.

The system status can be monitored through the Display Module or through an external system using the digital communications ports, for example, a Distributed Control System (DCS). The information here is mostly concerned with the Vortex Display Module.

The operation of the sounder and relays depends on the configuration of the relay logic (section 4.5.3). The details of systems configured by Crowcon are given in the Specification Sheet. For full details of the displays and controls on the Display Module, see section 4.6.

6.2 Monitoring with the Display Module

In normal operation all the LEDs in the channel status display are OFF. The system cycles through the channels, displaying each channel reading in turn for three seconds. The channel number is displayed in green, and the reading for the channel is displayed in red. The units of concentration are displayed by the illuminated green LED on the right of the Reading display.

For a gas detector, the concentration is displayed as %LEL (percentage of Lower Explosive Limit), %VOL (percentage by volume) or PPM (parts per million). These units can be configured in VortexPC.

NOTE: Detection occurs on all channels at all times. The display provides a view of the reading on a particular channel. The channel is not affected by this operation.

For a fire detector, a row of dashes appears on the Reading display when that channel is displayed and there is no alert condition. The word FIRE is illuminated on the green LED at the right of the Reading display.

To stop the cycling through the channels, and hold the reading of a particular channel, press the HOLD button when the channel is displayed. While the channel is held, the green LED next to the HOLD button is lit.

While the Display Reading is held, you can step to another channel by pressing the STEP button until the desired channel is displayed.

To return to the cycling display, press the RUN button. The Hold LED goes out.

6.3 Alarm conditions and faults

6.3.1 Display Module

If any channel detects an Alarm 1 or Alarm 2 condition, the corresponding LED for that channel flashes on the Display Module. Alarm 3 does not activate LEDs.

At the same time, the Channel display displays the channel reading for the affected channel. (This is called "Jump on Alarm" and can be disabled: see Appendix E.) The LED next to the Hold button flashes to indicate that the display is held on this channel. If further channels enter alarm, their associated red LEDs flash in the channel status display, but the Channel Display remains on the channel that first entered alarm. In this way, it is possible to determine which channel entered alarm first. This may help to locate the source of the problem.

If the alarm has been triggered by a fire detector, the Reading display shows the word "FIRE".

If any channel detects a fault condition, the yellow fault LED for that channel flashes on the Display Module and the Channel Reading shows the detected fault code, (section 6.4.1)

To confirm that you have seen the alarm or fault, press the ACCEPT/RESET button. If the alarm condition has already been cleared, the LED goes out. If the alarm condition still exists, the LED display changes from a flashing to a steady state. When the alarm has been cleared, press the ACCEPT/RESET button to clear the LED.

6.3.2 Internal sounder and relays

Alarm levels 1 and 2 and faults will activate the internal sounder and may activate relays depending on the relay logic configuration (section 4.5.3). Alarm 3 does not activate the sounder, but may be configured to operate relays.

To silence the audible alarm, press the ACCEPT/RESET button. The alarm relays may be reset, depending on the relay logic configuration.

On fire channels, pressing the ACCEPT/RESET button removes the fire loop current to try to reset latched fire/smoke detectors.

The internal sounder will also sound at a much lower rate during fire detector reset and stabilisation time (see section 4.2) following use of the ACCEPT/RESET button.

6.4 Fault Messages

6.4.1 Channel Faults

Vortex is able to detect and display faults relating to common problems in both gas and fire detectors.

On the Display Module, these faults are displayed as codes in the Reading display.

Table 17: List of channel faults

Code	Fault description
E	This is displayed when a fault is clearing. It is replaced by the normal reading in a few seconds.
E001	Channel Access fault. A problem with the communications between the Node Controller Module and Quad Channel Input Module has occurred. Check that all Quad Channel Input Modules are configured with the correct addresses.
E002	All inputs disabled. Restore inputs in accordance with the system specification before leaving the system in normal operation.
E006	Under Range fault (Open circuit). The current has fallen below 1mA for gas detector inputs, and less than the open circuit level for fire inputs. Check for open-circuit or wiring faults that cause abnormally low loop currents in detector wiring.
E007	Over Range signal (Short circuit). The current is greater than 23.5mA for gas detector inputs and greater than the programmed short circuit value for fire inputs. Check for short-circuit or wiring faults that cause abnormally high loop currents in detector wiring. Assume a high level of gas is present at the detector.
E008	Zero fault. This occurs only in Channel Test mode (section 7.4). The input is too far from 4mA to allow compensation. The input must be between 3.5 and 4.5mA. Check the detector output with a meter.
E009	Scale fault. This occurs only in Channel Test mode (section 7.4). The input is too far from the expected value to allow scale compensation. Check the detector output with a meter. Check that the detector has been calibrated correctly and the correct range has been configured.

6.4.2 Power Status

There is a Power Healthy LED on the Display Module, which provides information about the status of the various power systems.

Table 18: List of Power Status LED codes

Code	Fault description
Solid green	Mains power supply is good and the battery level is good.
Fast flashing green	Mains power supply is good but the battery level is low.
Solid yellow	Mains power supply has failed but the battery level is good.
Fast flashing Yellow	Battery level is low and mains power supply is disconnected.
Slow flashing yellow	Battery is discharged, disconnected, faulty or disconnected for deep discharge protection. Unlit Complete power failure or the Power Monitoring Module cannot be accessed on the bus.

6.4.3 System Faults

There are several system faults that are indicated by the System Fault LED on the Display Module.

The Fault LEDs on the Node Controller Module indicate what system error has occurred using a binary code.

Table 19: List of Node Controller Module LED fault codes

● = lit, ○ = unlit

Code	Fault description
○ ○ ○	No fault.
○ ○ ●	1 Battery fault. The battery is seriously discharged or disconnected. Reconnect or replace the battery. If no battery is fitted, ensure link LK1, on the power monitor module, is made.

○	2	FRAM data integrity fault.
●		Node Controller Module problem. Contact Crowcon.
○		
○	3	Internal bus fault.
●		Problem with the Ribbon Cable between the Display Module,
●		Node Controller and the Power Monitoring Module. Check the
		Ribbon Cable is connected and intact. If persists contact
		Crowcon.
●	4	Display access fault.
○		Check the connection between the Node Controller Module and
○		the Display Module. If persists contact Crowcon.
●	5	Power Monitoring Module access fault.
○		Check the connection between the Node Controller Module and
●		the Power Monitoring Module. If persists contact Crowcon.
●	6	External bus fault.
●		Ensure all modules are located on the Bus Rail correctly. If the
○		fault persists contact Crowcon.
●	7	Relay Module fault.
●		Relay Coil failure or access fault. Check all Relay Module
●		address switches are correct. If persists contact Crowcon.

7 MAINTENANCE

7.1 Detector Functional Testing

Crowcon recommends that you check detectors routinely to ensure correct calibration and operation.

For gas detectors, heads require recalibration at least every 6 months. Fire detectors should be tested every 3 to 6 months. Site procedures may require more frequent testing.

For detailed instructions on the routine functional testing of detectors, please refer to the relevant Installation, Operating and Maintenance Instructions provided with each detector.

7.2 Inhibiting input

During calibration (sections 3.8 and 7.3) or Channel Test (section 7.4), it is often necessary to inhibit the inputs so that relays are not tripped.

Using the Display Module, a zone (a group of four channels on a Quad Channel Input Module) can be inhibited by pressing the appropriate ZONE INHIBIT button on the back of the Display Module. To return the zone to normal operation, press the ZONE INHIBIT button again.

Using VortexPC, you can inhibit individual channels. See VortexPC Help.

When a zone or channel is inhibited, any alarm or fault condition detected on that channel is not transmitted to the relays. The Zone Inhibit LED is lit if the zone or any channel within the zone is inhibited.

7.3 Re-calibration of Vortex

Vortex does not normally require re-calibration. Calibration should be done whenever the following occurs:-

- a detector is changed
- a new detector is added
- replacement of certain modules see section 7.7.

In other cases, you may wish to carry out re-calibration as a confidence check.

The instructions below are for the Display Module. If you are using VortexPC, the software has Zero and Calibration Wizards to enable you to carry out the calibration easily.

To calibrate Vortex with a new detector, see section 3.8. A simpler procedure can be used for recalibration, or when a detector has been replaced. The PEAK HOLD CAL function provides a one person CAL facility. Vortex has a memory location for each of its twelve input channels. These memories store the highest value seen on each channel.

The Zero Adjustment should always be done before calibration.

1. For a new detector, calibrate the detector first. For the calibration procedure, please refer to the relevant Installation, Operating and Maintenance Instructions provided with the detector.
2. Inhibit the channel by pressing the appropriate ZONE INHIBIT button on the back of the Display Module. The calibration can be carried out without inhibiting the channel, but associated relays and audible and visual alarms may be triggered.
3. Ensure that the associated detector is reading zero level (4mA for a gas detector):
 - For an oxygen detector, the sensor must be disconnected from the current amplifier at the detector head.
 - For other gas detectors, the detector should be in free mobile air.
 - For a fire detector, the fire loop current connector must be disconnected at the Quad Channel Input Module.
4. Using the HOLD and STEP buttons, select the channel to adjust.
5. Once the display is held on the appropriate channel press the CHANNEL TEST button on the inside of the Display Module. The display should show GL for a gas detector or FL for a fire detector, and the detector level reading (this should be approximately zero).
6. Press the ZERO button. The display should read 0. If there is an E008 fault, it indicates that the incoming signal is too far from the nominal zero level to allow compensation. Check that the detector is wired correctly and the Quad Channel Input Module switch setting is correct.
7. Provided that zero adjustment was successful, reconnect the sensor (for oxygen detectors only) or connector (for fire detectors only).
8. With Vortex not in Channel Test, press PEAK HOLD CAL to clear the memory.

9. For an oxygen detector, expose the detector to free mobile air. Ensure that the display is showing GL and the current gas level reading. Allow this reading to stabilise. For other gas detectors, apply calibration gas to the detector (normally half scale, but must be greater than 20% of full scale). Allow enough time for the detector to settle (typically two minutes). Ensure that the display is showing GL and the current gas level reading. Allow this reading to stabilise. For a fire detector, connect an ammeter into the channel circuit. Ensure that the display is showing FL and operate a manual call point. If the circuit has no manual call point, put a detector into alarm with a smoke canister.
10. Press the PEAK HOLD CAL button.
11. Use the – (HOLD) and + (STEP) buttons to adjust the Reading display to the correct reading:
 - For an oxygen detector in free mobile air calibrate to a reading of 20.9% Vol.
 - For other gas detectors, this should be the level for the applied calibration gas.
 - For other 4-20mA devices this should be the level for the applied condition.
 - For a fire detector, this should be the same reading as the ammeter in the circuit.
 Press ACCEPT/RESET. The display should read the calibration gas concentration (for a gas detector) or the current in mA (for a fire detector).
 If there is an E009 fault, it indicates that the mA output from the detector and the required reading are too far apart to allow compensation. The detector calibration should be checked.
13. The detector and Quad Channel Input Module are now configured and calibrated correctly.
 - For a gas detector (other than oxygen), remove the calibration gas.
 - For a fire detector, remove the ammeter and reconnect the fire loop.
14. Press the RUN button on the front of the Display Module to release the Channel Test Mode.
15. Release any Inhibit Conditions by pressing the appropriate ZONE INHIBIT button.
16. If necessary select another channel and repeat the procedure until all channels requiring calibration are complete.

7.4 Channel Test Mode

Channel Test mode is used to view and modify the alarm level settings for a channel, using the Display Module, and to test the configuration of relay outputs.

Channel Test mode is also needed in order to carry out calibration and re-calibration operations (see sections 3.8 and 7.3).

7.4.1 Channel Test Mode procedure

During Channel Test mode, all gas detection and relay functions are unaffected, except for the selected channel. The internal sounder is not used to sound alarms during Channel Test mode. The detector level readings transmitted over the MODBUS communications link are affected in this mode, contact Crowcon for more details.

If you wish to test simple relay configurations, you can use this procedure with the zones not inhibited. Note that the fault condition step in Channel Test mode does not cause any relays to be triggered.

To view the channel settings:

1. Select the required channel with the HOLD and STEP buttons.
2. Press the ZONE INHIBIT button for each of the channels you intend to test, in order to avoid operation of the relays, unless you wish to check the relay output configuration.
3. Press the Channel Test button on the back of the Display Module.
 If the channel is a gas detector (or any other 4-20mA input device), the Channel display shows the code GL (for Gas Level), and the Channel Test LED flashes. The gas reading is displayed in the Reading display.
 If the channel is a fire detector, the Channel display shows the code FL (for Fire Level), and the Channel Test LED flashes. The loop current is displayed in the Reading display in milliamps.
 The readings are displayed without zero suppression.
4. Press the Channel Test button repeatedly to display the levels in the order shown in Table 20. If the channel is not inhibited, the relays are tripped as the sequence passes through them. This can be used to test that the relays and their devices are working correctly.

Note that the individual alarms are operated independently, depending on their thresholds and whether they are set as rising or falling, so more than one alarm may be present at one time.

Table 20: Channel test display sequences

Gas detector channel		
Channel display	State	Reading display
GL	Starting point. Alarm status according to input signal level.	Gas Level
A1	Alarm level 1 active	Alarm Level 1
A2	Alarm level 2 active	Alarm Level 2
A3	Alarm level 3 active	Alarm Level 3
FS	All rising alarms active	Full Scale
A3	Alarm level 1 active	Alarm Level 3
A2	Alarm level 2 active	Alarm Level 2
A1	Alarm level 3 active	Alarm Level 1
0	All falling alarms active	Zero
F (Fault)	Fault LED is on solidly. A zero level is forced so that falling alarms are active. This test does not trigger the fault relay.	E (possibly with a fault number)
GL	Back to starting point	Gas Level
Fire detector channel		
FL	Starting point. Alarm status according to input signal level.	Fire Level
OC	No alarms active. Fault active	Open Circuit
AL	Alarm levels 1,2 and 3 active. No fault active.	Alarm Level
SC	Alarm levels 1, 2 and 3 active and fault active.	Short Circuit

Channel display	State	Reading display
FS	Alarm levels 1, 2 and 3 active and fault active.	Full Scale
0	No alarms active. Fault active.	Zero
FL	Back to starting point	Fire Level

5. Press the RUN button to end the Channel Test at any point.
6. Cancel any zone inhibits by pressing the appropriate ZONE INHIBIT buttons.

7.4.2 Setting alarm levels

To change an alarm level:

1. Press the appropriate ZONE INHIBIT button for each of the channels you intend to test.
2. Select the required channel with the HOLD and STEP buttons.
3. Use the Channel Test button to display the appropriate level (A1, A2 or A3). (See section 7.4.1.)
4. Press the + button (STEP) to increase the value or the – button (HOLD) to decrease it. Repeat until the required value is displayed.
5. To store the new value in the Vortex memory, press the ACCEPT/RESET button. The internal sounder beeps. If you do not do this, the change is lost on the next press of the Channel Test button.
6. To return to normal operation, press the RUN button on the front panel.
7. Cancel any zone inhibits by pressing the appropriate ZONE INHIBIT buttons.

NOTE, for fire detectors a similar method is used to adjust the short circuit, alarm and open circuit levels when the channel display is reading SC, AL and OC respectively.

7.5 Lamp test

The lamp test is used to check that all LEDs and the sounder are working. It also tests the confidence LED and the fault LEDs on the Node Controller Module. This test can be carried out at any time except in Channel Test mode. It does not affect the gas or fire detection.

To carry out the test use one of these methods:

- Press the LAMP TEST button on the Display Module.
- Operate the Lamp Test switch on the Node Controller Module.
- Connect the terminals 10 and 11 on the Node Controller Module.

The test operates only while the button, switch or connection is held.

7.6 Event logging

The Node Controller Module logs events (300 maximum) which can be accessed through the digital communication links. Each event is recorded with a time stamp. Table 21 lists data recorded in the event log.

Table 21: Data recorded in the Event Log

Event	Data recorded
Entry and exit from alarm states	Each channel ID and alarm level
Fire detector coming online after a reset and stabilisation period	Channel ID
Accept/Reset action	
Channel test actions	Action performed and channel ID.
Clearing of the Peak Hold Cal memories	
Inhibit action	Channel ID and whether inhibit condition set or cleared
Fault (each fault is recorded as fault occurred and fault fixed)	Under-range, Over-range, Channel communications access together with relevant channel ID No detector enabled fault
System faults (each fault is recorded as fault occurred and fault fixed)	Battery fault, FRAM data, Ribbon Cable bus, Display Access, Power Monitoring Module, Module Access, Bus PCB, Relay Output Module
Relay drive output	Relay ID and whether the relay is driven or not driven. This is the result evaluated by the relay logic and not necessarily the relay contact state as this is dependent on the relay configuration.
Communications actions	Config cable inserted, Config cable removed. Zero and cal operation performed over serial communications with associated channel ID.
FRAM update	The internal stored configuration Power supply event Change in the power supply occurred and changed to OK / Mains Fail, Battery Low / Mains OK, Battery Disconnect / Mains OK, Battery Low
Service event	Date and time that the event log was cleared

7.7 Module replacement

Vortex is a modular system, and modules can be replaced as necessary. The electronic boards contained within the modules are not serviceable. If replacement modules are used, ensure that any configuration switches are set correctly before they are inserted into the system (see chapter 4). The error E001 may occur if the module address switches are incorrectly set.

See Appendix C for the list of available spare parts.

Modules can be changed without creating an error state if the Hot Swap facility of the Node Controller Module is used.

1. To use Hot Swap, connect node controller terminal 9 to terminal 12 while in run mode (not held on a channel). See Figure 17 in Appendix B. During Hot Swap, the sounder sounds repeatedly and the Reading display shows the word "Stop". The system stops monitoring, but relays remain unchanged.
2. Change the required modules. For instructions on mounting and dismounting the modules, see section 7.8.
3. Remove the "hot swap" connection. The previous state of the Vortex system is restored and the sounder stops.

Changing certain modules can give rise to the need to recalibrate as defined below;

Replacement of:-	Calibration Required
Node Controller Module	All channels
Quad Channel Input Module	Channels connected to replaced card

7.8 Mounting and dismounting DIN Rail modules

Modules plug into the sockets on the DIN Rail, and are held on by the plastic clips. See Figure 14.

1. To mount a module, position the top and bottom black clips in their positions closest to the plug at the back of the module. Push the module so that the plug engages with the socket on the DIN Rail, then push firmly until the clips engage with the DIN Rail.
2. To dismount a module, lift the top clip and lower the bottom clip using a screwdriver, as shown in Figure 14. Pull the module off the DIN Rail.

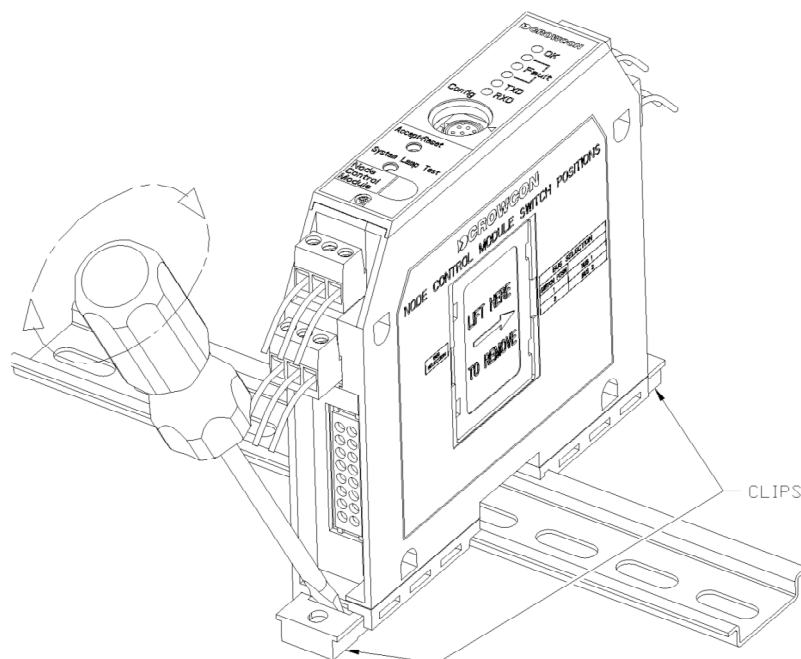

Figure 14: Module on DIN Rail, and method of removal

7.9 Changing the Batteries

To change the batteries in Vortex DIN, Vortex Rack and Vortex Panel, simply disconnect the old batteries from the Power Monitoring Module and connect the new ones. It is not necessary to remove the power in order to carry out this function.

To change the batteries in Vortex in the standard enclosure follow the instructions below. The backup batteries can be changed without switching the power off.

1. Disconnect the batteries at the top right of the Power Monitoring Module (see Figure 11).
2. Unscrew the two large central screws on the Power Monitoring Module and gently pull it out without disconnecting any other cables (see Figure 15).
3. Unscrew the three screws holding the metal bracket over the front of the battery compartment. Remove the bracket.
4. Change the batteries. Tuck the fuse into the space at the right of the batteries and ensure that the connecting wires to the Power Monitoring Module are out at the top.

5. Screw in the bracket and the Power Monitoring Module.
6. Connect the batteries to the Power Monitoring Module.

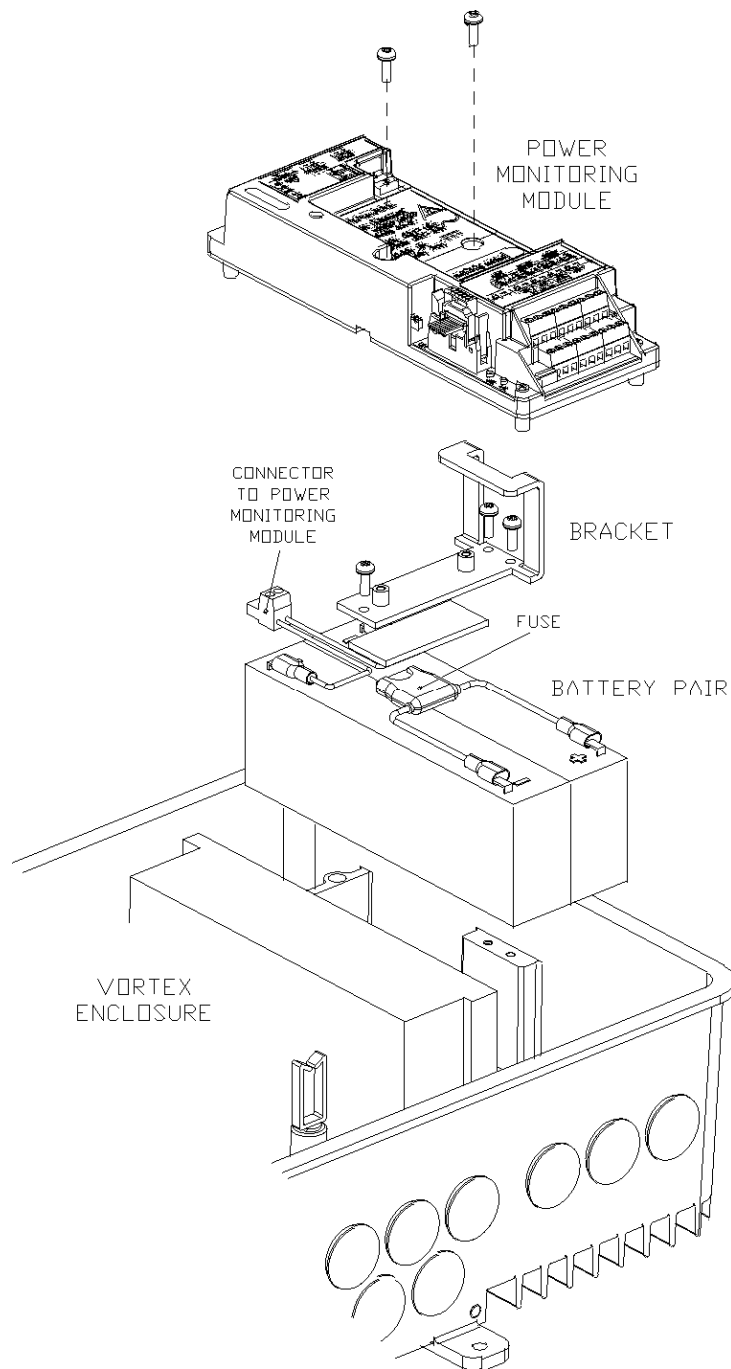

Figure 15: Removing batteries from Vortex Standard Enclosure

Note: for clarity, cables have been omitted from the diagram. This operation can be carried out without disconnecting the Power Monitoring Module from the system, as described in the text.

APPENDIX A: GLOSSARY

This manual uses the following terminology, acronyms and abbreviations.

%LEL	Percentage of Lower Explosive Limit: a way of expressing the concentration of a flammable gas.
%VOL	Percentage by Volume: the concentration of a gas expressed as a percentage of the total volume of the mixture of gases. Also abbreviated to v/v.
DCS	Distributed Control System
EMC	Electromagnetic Compatibility
FRAM	Ferro-electric Non-volatile RAM, this is the type of non-volatile memory used in the Vortex node controller module.
Inhibit	Breaking the link between a channel and the associated outputs; this is to avoid generating an alarm while testing or calibrating a detector.
IS	Intrinsically safe: used to describe a device or circuit designed not to produce a spark or thermal effect capable of igniting a given flammable atmosphere.
LED	Light Emitting Diode
Modbus	Protocol used on RS485 and RS232 interconnections
PC	Personal Computer
PCB	Printed Circuit Board
PLC	Programmable Logic Controller
ppm	Parts per million: a measure of gas concentration when the concentration is very small.
Relay Logic	The interconnection between detectors and relays, handled by the Node Controller Module.
RS232	Hardware serial communications standard between personal computers and Vortex. The Vortex system works with the Modbus protocol over this link.
RS485	Master-slave serial communications standard, used between PLCs or DCSs and Vortex. The Vortex system works with the Modbus protocol over this link. This standard is multi-drop, that is, a number of Vortex systems can be controlled by a single master system.
Sink (detector configuration)	One side of a sink detector is connected directly to ground. The relevant channel should be configured for the detector used. See the detector specification sheet to see whether it is source, sink or dual.
Source (detector configuration)	One side of a source detector is connected directly to the supply. The relevant channel should be configured for the detector used. See the detector specification sheet to see whether it is source, sink or dual.
SPCO	Single Pole Changeover; a type of relay.
SWA	Steel wire armoured, a type of cable which is enclosed in steel wire for protection.
Zero	The process of offsetting inputs to account for detectors which do not give exactly 4mA.

Zero Suppression	An option that applies to gas detectors. When this option is selected (the default), readings less than 3% of full scale are suppressed to zero. See section 4.4.2.
Zone 1, 2, 3	In the Vortex system, refers to the four detector channels in one Quad Channel Input Module. Not to be confused with the standard terms used in classifying hazardous areas.

APPENDIX B: ELECTRICAL CONNECTIONS

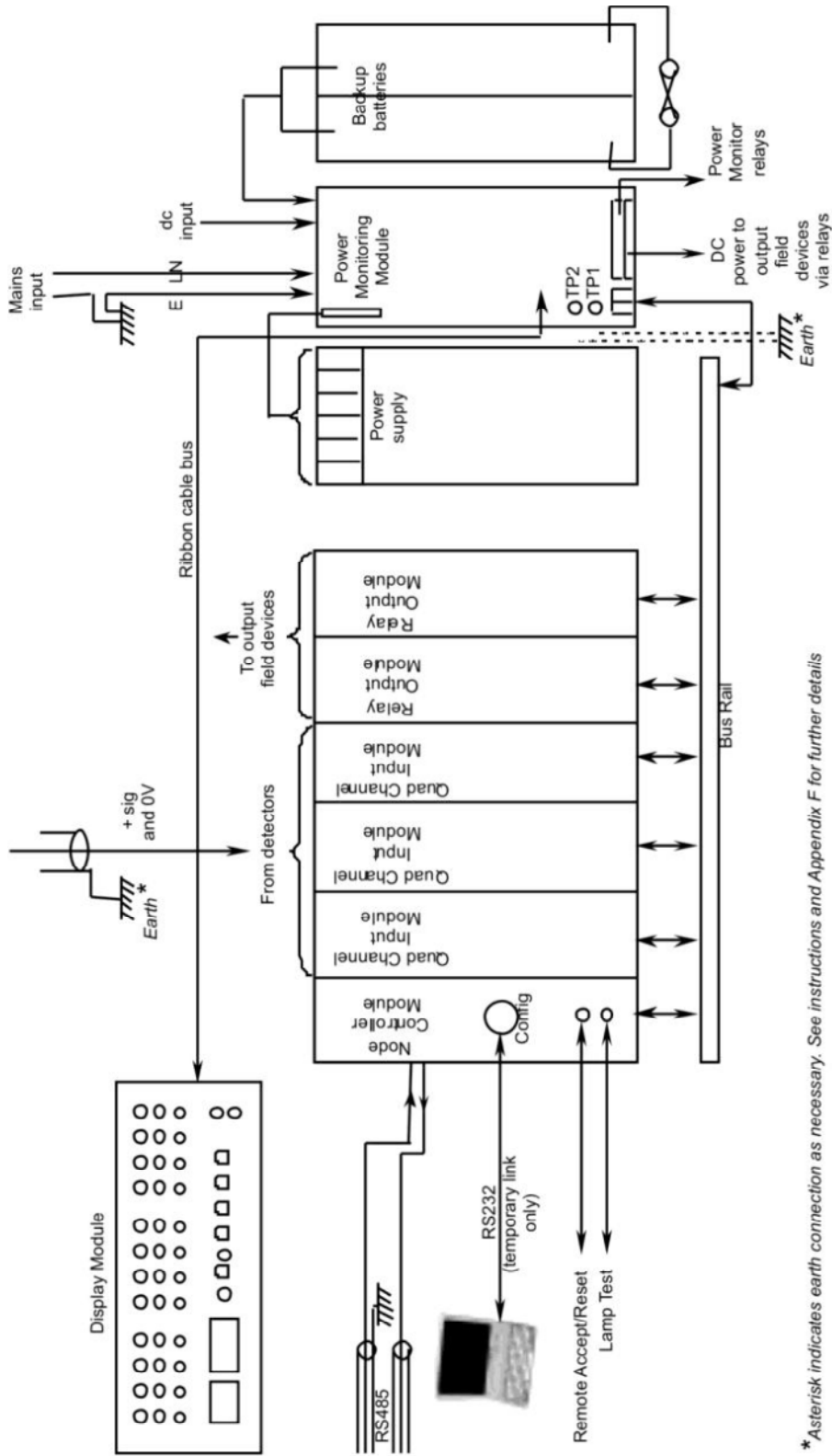

* Asterisk indicates earth connection as necessary. See instructions and Appendix F for further details

Figure 16: Connection schematic for the Vortex system

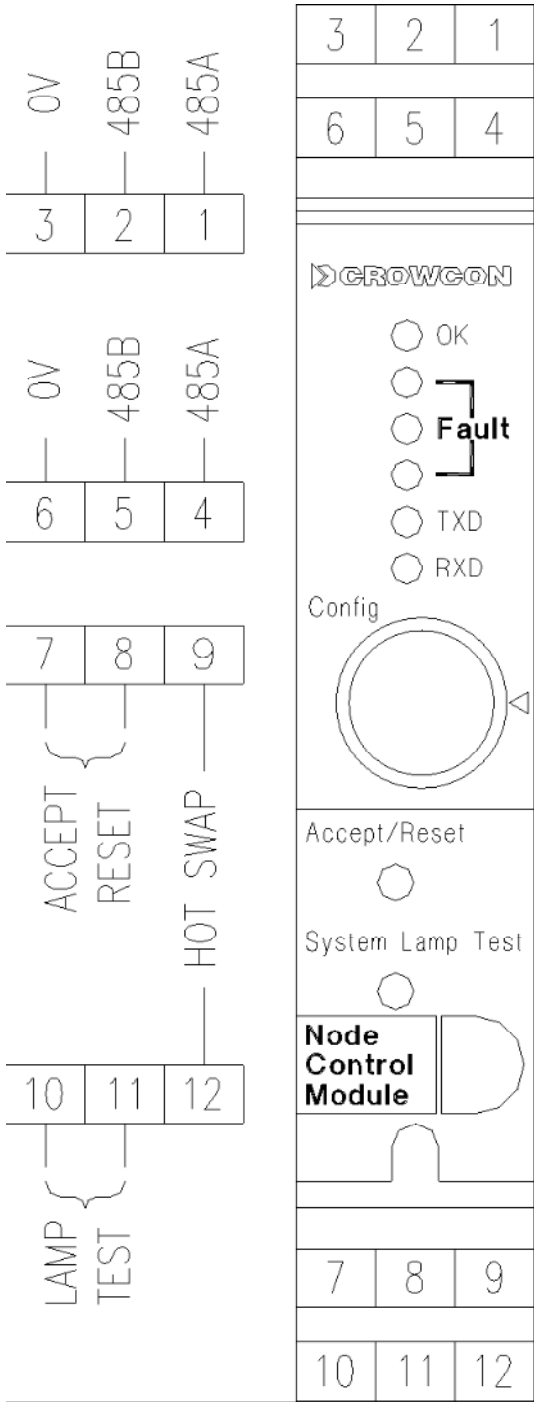

Figure 17: Wiring diagram for the Node Controller Module

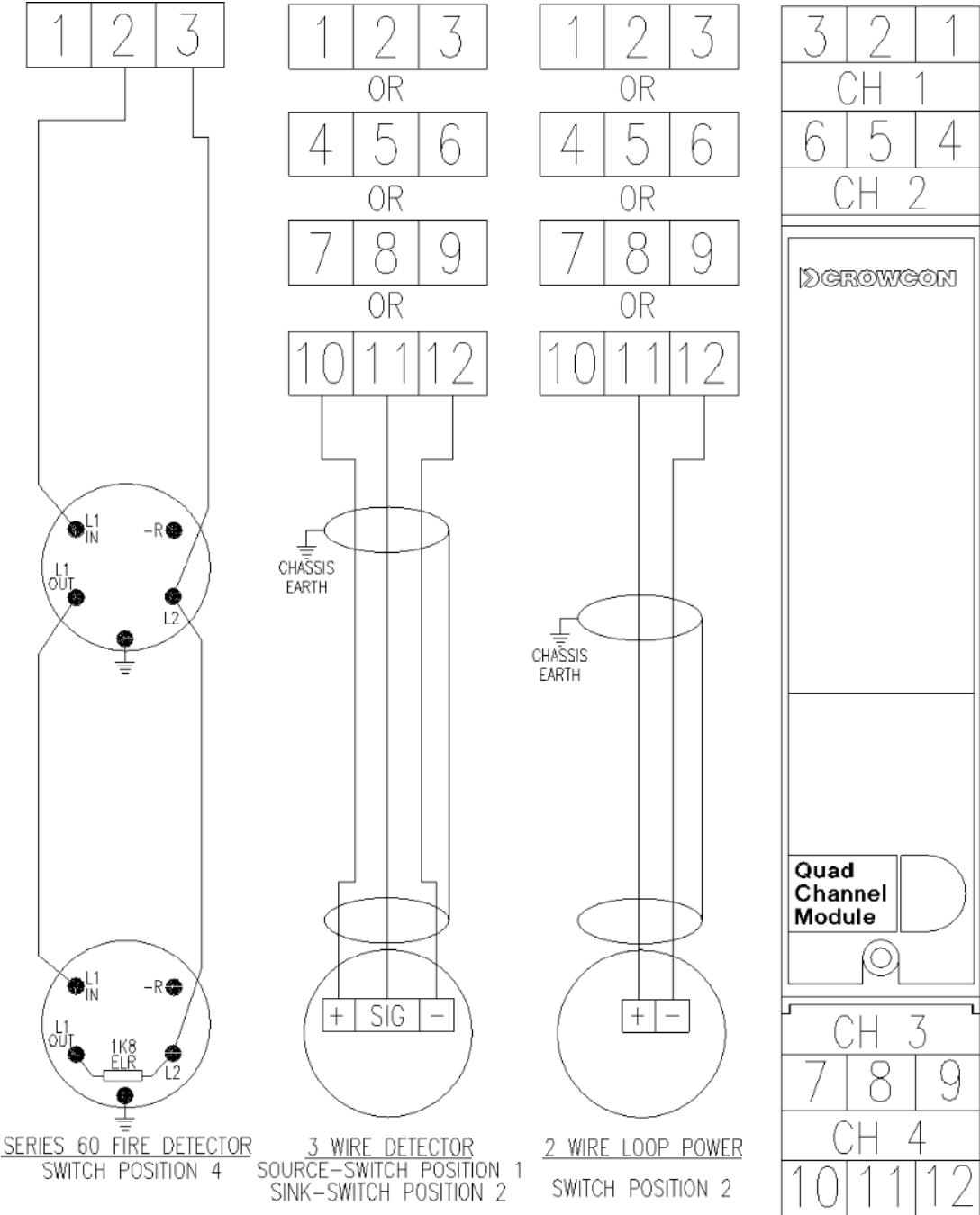

Figure 18: Wiring diagram for the Quad Channel Input Module

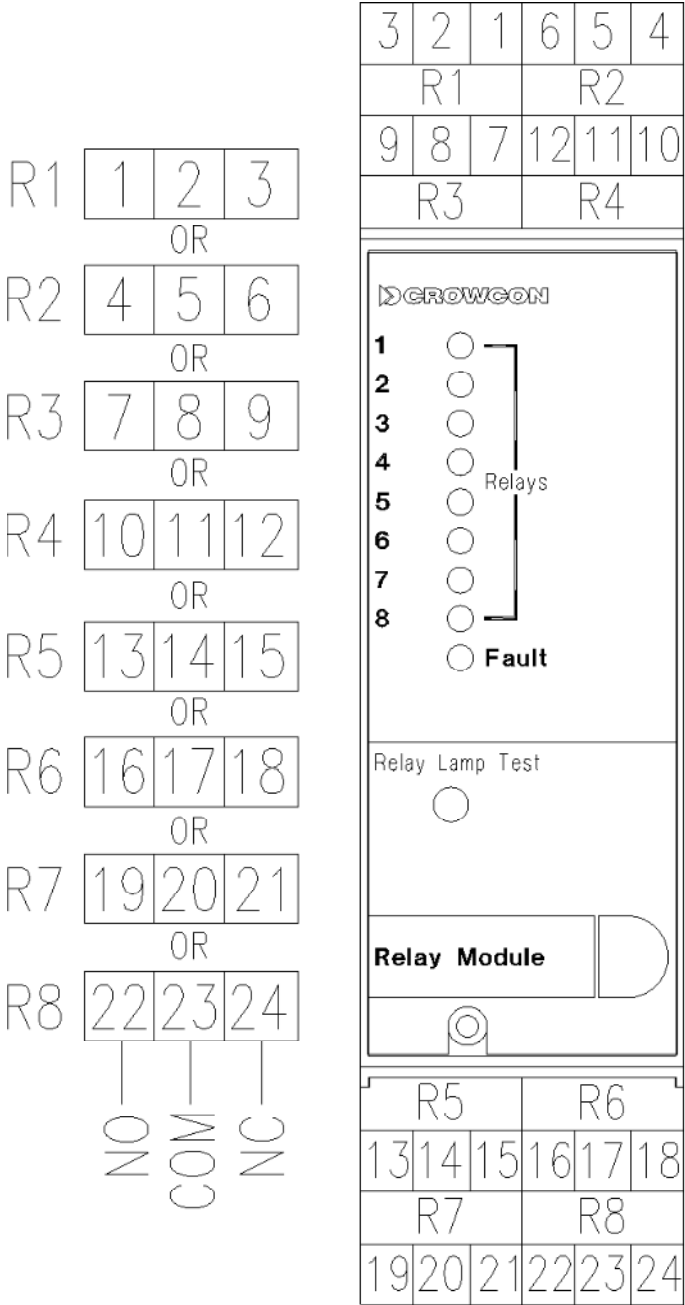

Figure 19: Wiring diagram for the Relay Output Module

APPENDIX C: LIST OF SPARE PARTS

Description	Part Number
Node Controller Module	S01937
Quad Channel Input Module	S01935
Relay Output Module	S01939
Vortex Display Module (wall mount version)	S01913
Rack Display Module	S011030
Panel Display Module	S011029
Panel Overlay Label	M05746
Power Monitoring Module	S01941
Instruction Card	M07212
M20 plastic gland plug	M04561
Key	M02315
RS232 communications cable	E07533
Vortex Ribbon cable assembly	E07524
Vortex Rack/Panel/DIN ribbon cable	E07554
3 way connector	E07101
2-way connector	E07100
VortexPC software	C01758
DIN Rail Mounting Kit for Power Monitor Module	C01794
Vortex Bus Spares Assembly	C01768
Vortex Bus extension kit	C01800

APPENDIX D: CROWCON DETECTOR RANGE

The following list gives details of some of Crowcon's detectors, in manufacture currently, for use with Vortex. This list is not definitive as new products are being added to the range all the time. For the most up to date information refer to the Crowcon Web page at www.crowcon.com.

Product Name	Type of Detector	Typical Range/Gas
Xgard Type 1	Electrochemical. 2-wire 4-20mA sink, loop powered, local amplifier. Output is proportional to the gas concentration at the detector. Intrinsically safe.	Various ranges. Most toxic gases, oxygen.
Xgard Type 2	Electrochemical. 2-wire 4-20mA source or sink, loop powered, includes a local amplifier. Output is proportional to the gas concentration at the detector. Sink device. Flameproof.	Various ranges. Oxygen, carbon monoxide, hydrogen, and hydrogen sulphide.
Xgard Type 3	Pellistor/catalytic bead. 3-wire mV bridge output. Requires converter to Connect to Vortex. Output is proportional to the gas concentration at the detector. Flameproof.	0-100% LEL Most flammable gases.
Xgard Type 4	Pellistor/catalytic bead. High temperature version: operation up to 150°C. 3-wire mV bridge output. Requires converter to connect to Vortex. Output is proportional to the gas concentration at the detector. Flameproof.	0-100% LEL. Methane.
Xgard Type 5	Pellistor/catalytic bead. 3-wire 4-20mA source or sink output, includes a local amplifier. Output is proportional to the gas concentration at the detector. Flameproof.	0-100% LEL. Most flammable gases.
Xgard Type 6	Thermal conductivity. 3-wire 4-20mA source or sink output, includes a local amplifier. Output is proportional to the gas concentration at the detector. Flameproof.	0-100% vv. Suitable for binary gases only.

Product Name	Type of Detector	Typical Range/Gas
TXgard-IS+	Electrochemical. 2-wire 4-20mA sink, loop powered, local amplifier with display. Output is proportional to the gas concentration at the detector. Intrinsically safe.	Various ranges. Most toxic gases, oxygen.
TXgard Plus	Electrochemical. 3-wire 4-20mA source or sink output, includes a local amplifier and display. Output is proportional to the gas concentration at the detector. Flameproof.	Various ranges. Oxygen, carbon monoxide and hydrogen sulphide only.
Flamgard Plus	Pellistor/catalytic bead. 3-wire 4-20mA source or sink output, includes a local amplifier and display. Output is proportional to the gas concentration at the detector. Flameproof.	0-100% LEL. Most flammable gases.
IRmax	Infrared. 3-wire 4-20mA source and sink output, includes a local amplifier and display. Output is proportional to the gas concentration at the detector. Flameproof.	0-100% LEL. Many hydrocarbon gases and vapours.
Xgard IR	Infrared. 3-wire 4-20mA source and sink output, includes a local amplifier. Output is proportional to the gas concentration at the detector. Flameproof.	0-100% LEL. Methane, butane, propane, ethylene, ethanol, pentane, hexane, LPG 0-2 or 0-5% CO ₂ .
TCgard	Thermal conductivity. 3-wire 4-20mA source or sink output, includes a local amplifier. Output is proportional to the gas concentration at the detector. Flameproof.	0-100% vv. Suitable for binary gases only.

Detailed Installation, Operating and Maintenance Instructions are supplied with each type of detector. Read these instructions before connecting the detector to Vortex and applying power.

Detectors not listed may still be used with Vortex. For further details contact Crowcon.

APPENDIX E: VORTEX CONFIGURATION

The following list shows all the configurable options in the Vortex system. These can be configured from VortexPC.

Option/Property	Allowed values and explanation
System	
System Name	16-character string used to identify the system
Enable Jump on Alarm	On/Off. If this option is set, the first channel that causes an alarm is automatically held on the display. The Hold LED flashes. The display remains held, even if other channels go into alarm, until the RUN button is pressed.
Disable Local Buttons	Y/N. If Y then CAL, ZERO, PEAK HOLD CAL, CHANNEL TEST buttons have no effect
Disable Internal Sounder	Y/N. If Y, the internal sounder is disabled. Modbus address The Modbus address of the Vortex on the system. Usually 1 unless the system is multidrop.
Number of Quad Channel Input Modules	1, 2 or 3
Number of Relay Output Modules	0, 1, 2, 3 or 4
Channels	
Identity	8-character string used to identify the channel.
Enabled	On/Off. A detector must be enabled and configured to participate in the system. If there are no participating detectors, an E002 error is generated.
Type	Gas Fire (Channel 1 of module only) Not Configured if channel has no detector
Gas detectors	
Units	Selects the units for Gas Detectors: %LEL, %VOL or ppm.
Range	For %LEL and %VOL the range can be 0 to 1, 2, 2.5, 5, 10, 20, 25, 50 or 100. For ppm the range can be 0 to 1, 2, 2.5, 5, 10, 20, 25, 50, 100, 200, 250, 500, 1000, 2000, 2500, 5000, 10000. For the 10000 range, the maximum display is 9990.
Out of range values	Interpret High and Interpret Low. Each option can be set to Info, Inhibit or Fault. For details, see section 4.4.2.
Alarm Levels 1, 2 and 3	The alarm thresholds must be set within the range for the detector, using the units specified. The alarm level is either Rising or Falling.
Zero suppression	On/Off. The default is On. When this option is selected, the readings less than 3% of full scale are suppressed to zero. For details, see section 4.4.2.

Option/Property	Allowed values and explanation
Fire detectors	
Current thresholds	The current thresholds must be set within the range 0 to 60mA, in the order Open Circuit < Fire < Short Circuit Reset time Between 0 and 255 seconds. The time that the loop current is removed to reset a latched fire detector on pressing ACCEPT/RESET after a fire alarm. Stabilisation time Between 0 and 255 seconds. The time allowed for the fire detector to stabilise after a reset before coming on line.
Relays	
Identity	8-character string used to identify the relay
Enabled	On/Off. A relay must be enabled and configured to participate
Type	This can be set to Not Configured, Non-Latching, Non-Latching Acceptable, Latching, Latching Acceptable, Pulsed or Reset Pulse. Unused relays must be set to Not Configured. Explanations are given in section 4.5.2.
ON delay time	The waiting period before the relay is activated. Where applicable, 0 to 65535 seconds.
OFF delay time	The waiting period before the relay is de-activated, except for Pulsed and Reset Pulsed, where it is the period for which is relay is activated. Where applicable, 0 to 65535 seconds.
Energisation	Normally Energised or De-energised. See section 4.5.2.
Relay logic	
Detector Links	Allow detector alarms and events to be mapped to relay logic, see section 4.5.3
System Links	Allow the system fault and system sounder to be mapped to relay logic, see section 4.5.3
Vote Count	The count is between 1 and the number of inputs to the relay, and is the number of inputs required to trigger the relay. See section 4.5.3.

APPENDIX F: EARTHING

Introduction

The following decision tree and the accompanying diagrams can be used to establish the earthing needed for your system.

Definitions

Intrinsic Safety Earth	The earthbar connection to the zener barriers. It should have its own unique cable connection back to a central grounding point.
Isolated power supply	A power supply where the 0V line is not connected to the earth terminal. The internal power supply in Vortex is isolated.
Galvanic isolator	An alternative to a zener barrier that does not require the high integrity earth.
Zener barrier	A device used to implement a safe interface between a safe and a hazardous area. The device limits the amount of voltage and current that can enter the hazardous area, in order that sparks or heat caused by an electrical fault in the safe area do not cause an ignition hazard in the hazardous area. Zener barriers require a high integrity earth (ground) connection, sometimes known as the Intrinsic Safety Earth.

Questions

These questions are referred to in Figure 20 The possible answers are also listed. Answer the questions and follow the tree until it refers to the diagrams which should be used as a guide to wiring and earthing requirements.

Question no.	Question	Possible answers
1	How many sensors require the use of zener barriers OR galvanic isolators?	NONE SOME ALL
2	Does the system use the Vortex internal mains to DC power supply?	YES NO
3	Is the external mains to DC power supply isolated?	YES NO
4	Is the safe area interface via a zener barrier device?	YES NO

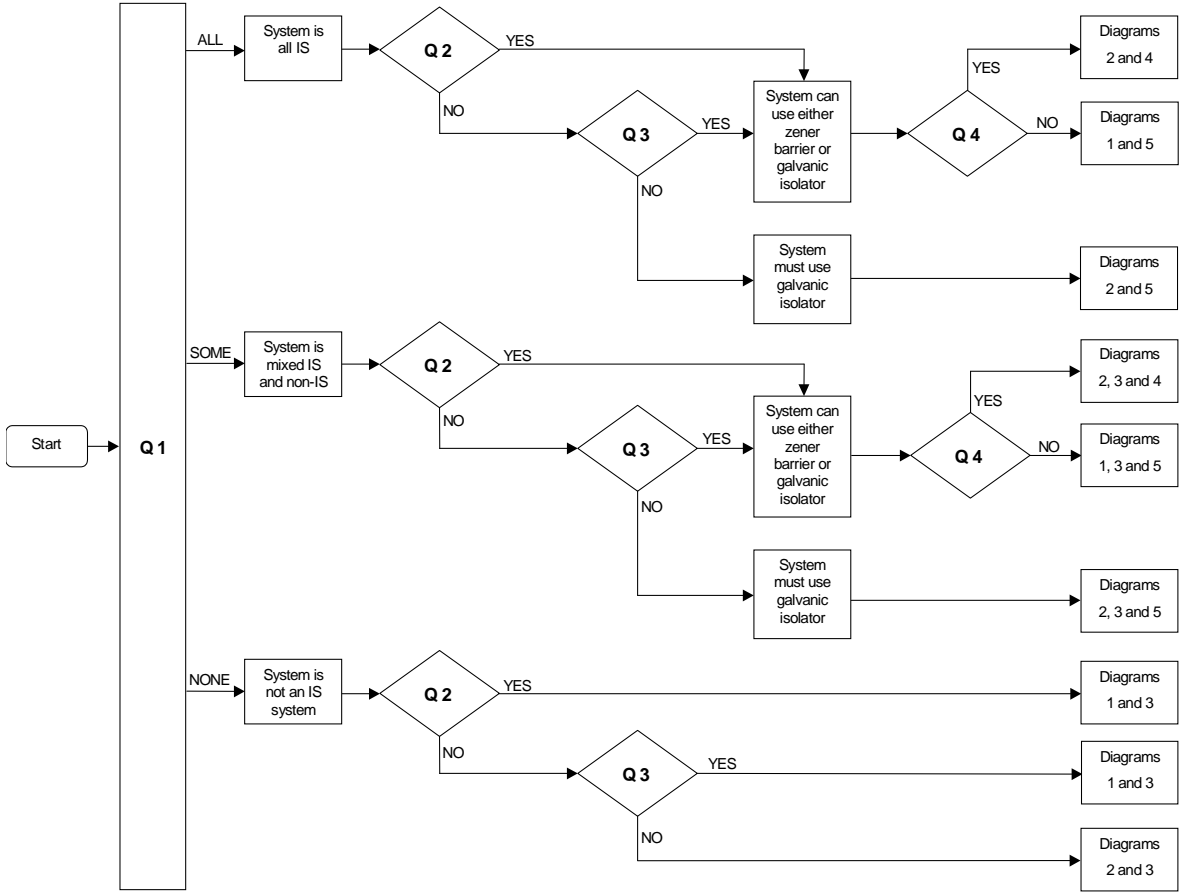

Figure 20 Decision Tree for determining Earthing Requirements

Diagrams

Diagram 1

Connect Vortex chassis (earth) to TP1 on the Power Monitoring Module

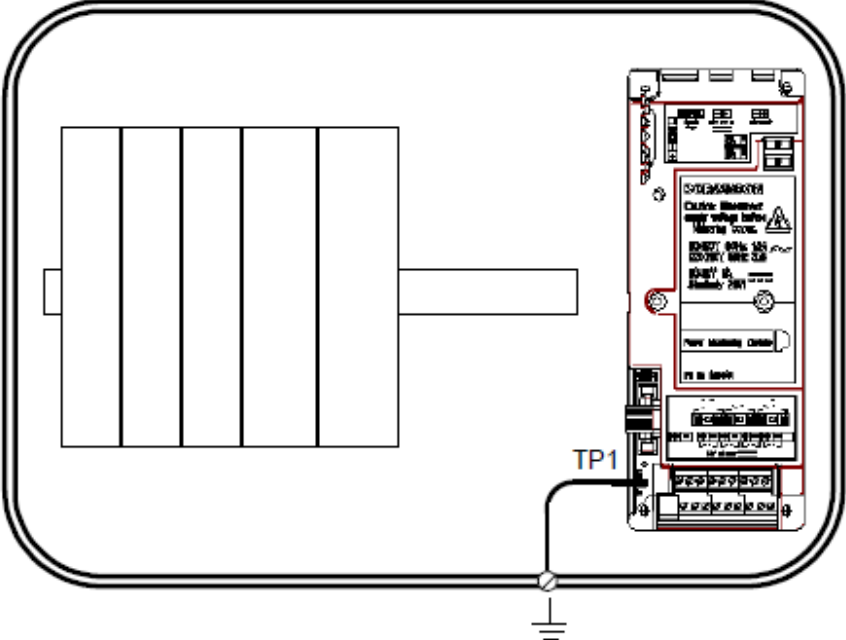

Diagram 2

Connect Vortex chassis (earth) to TP2 on the Power Monitoring Module.

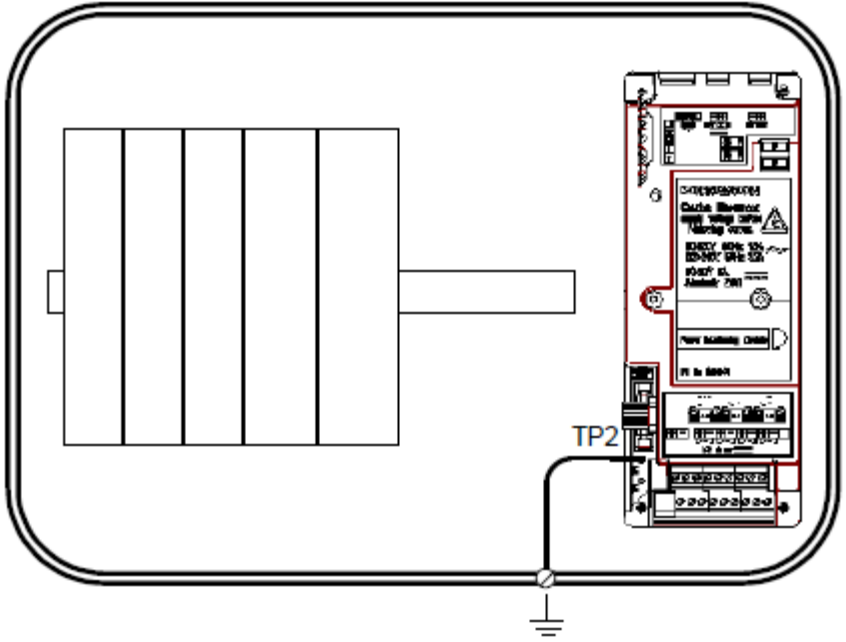
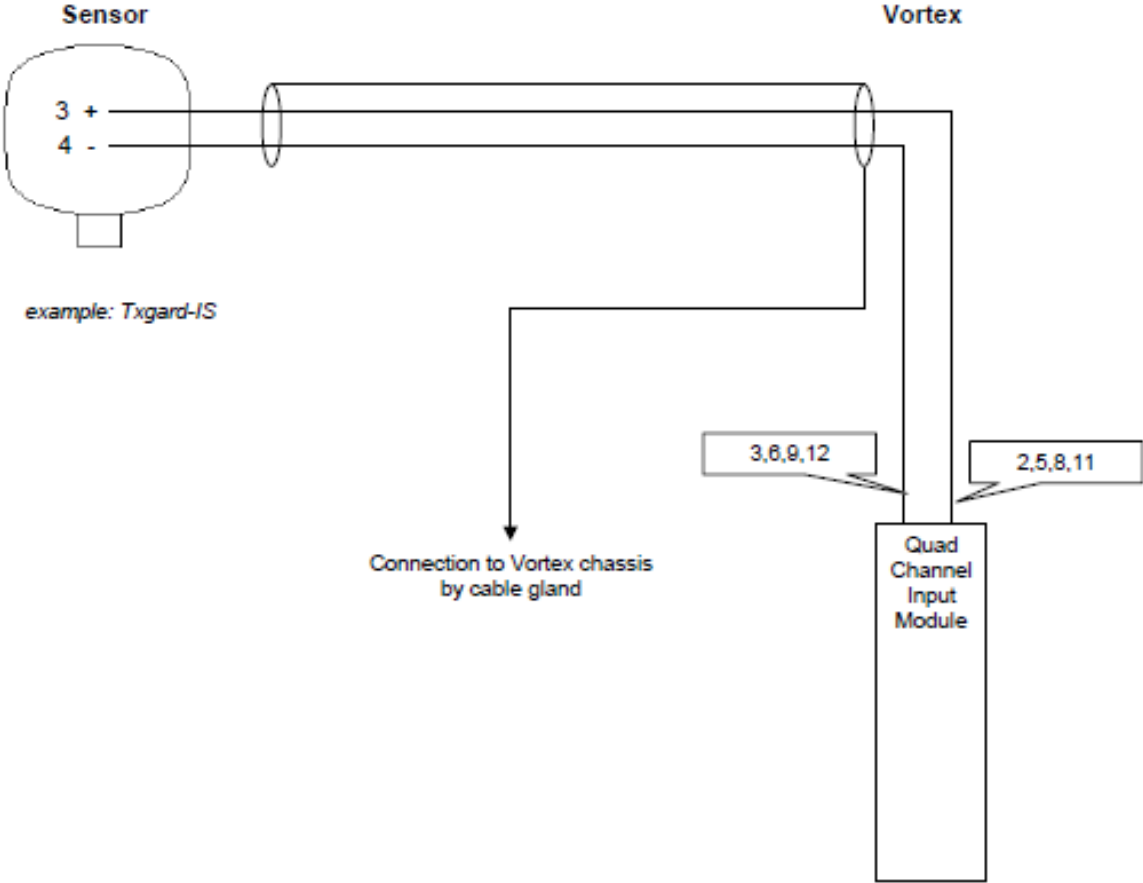

Diagram 3

Sensor connection to Vortex without barrier or isolator.

2-wire



3-wire

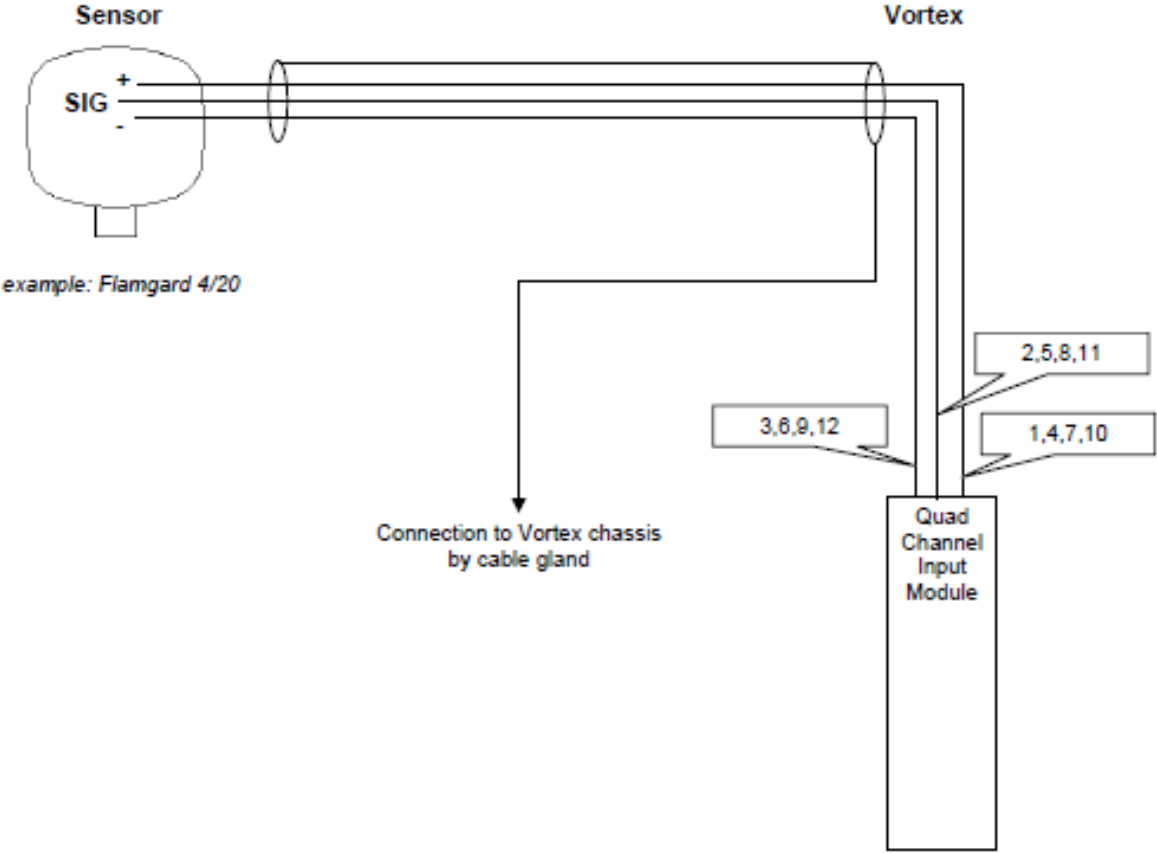

In a system with mixed IS and flameproof sensors in a hazardous area (Zone 1 or 2), the flameproof sensors can be connected as shown above providing the sensor complies with relevant standards.

Diagram 4A

Gas sensor connection to Vortex via a zener barrier.

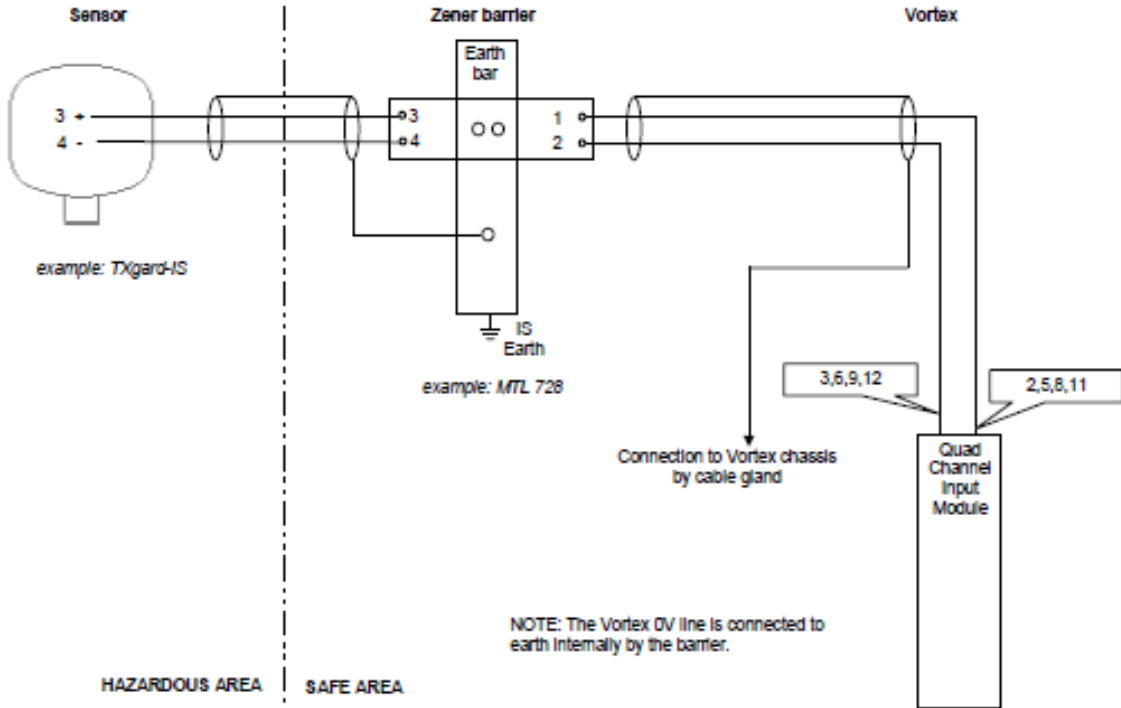

Diagram 4B

Fire detector connection to Vortex via a zener barrier.

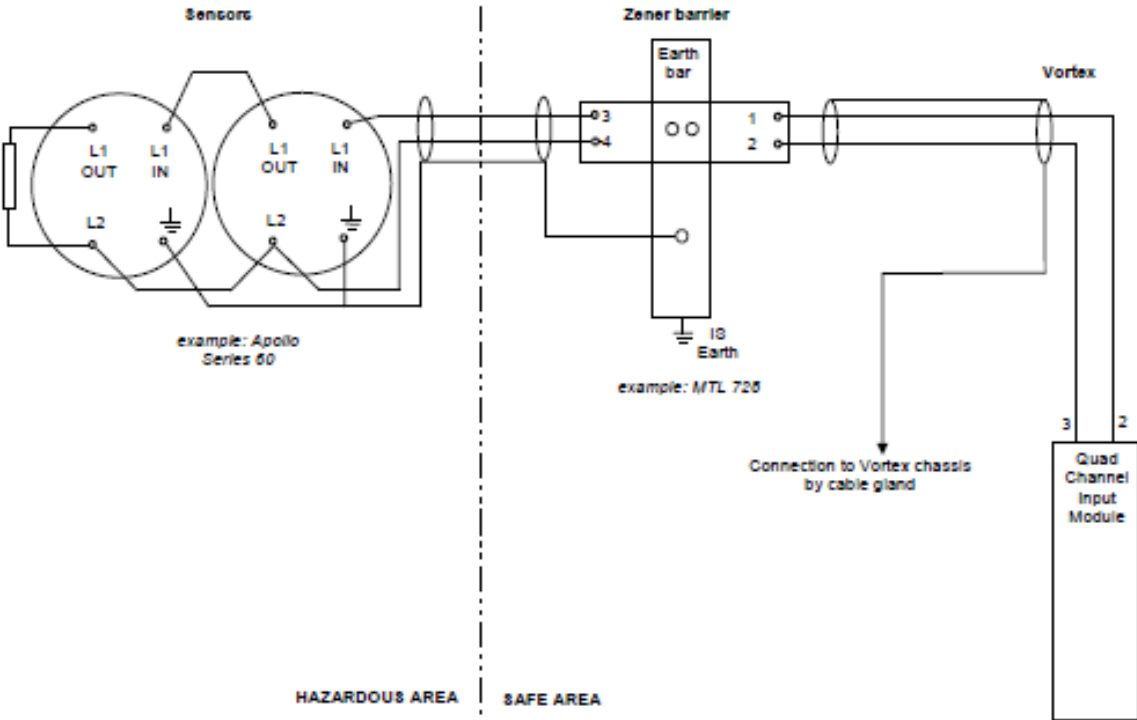

Diagram 5A

Gas sensor connection to Vortex via a galvanic isolator.

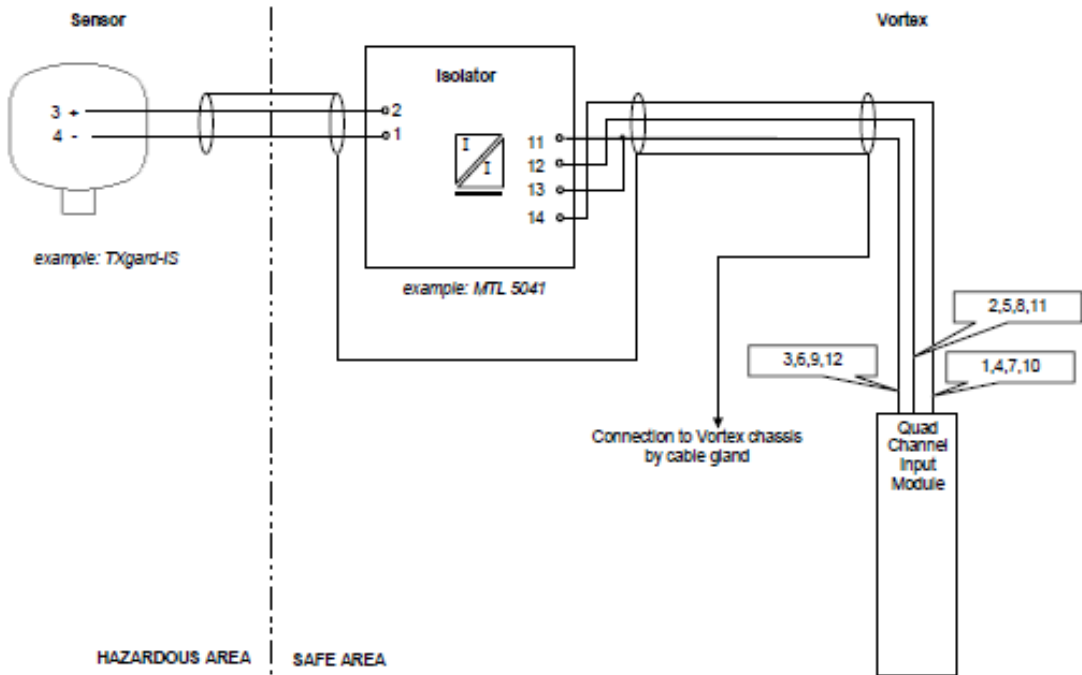
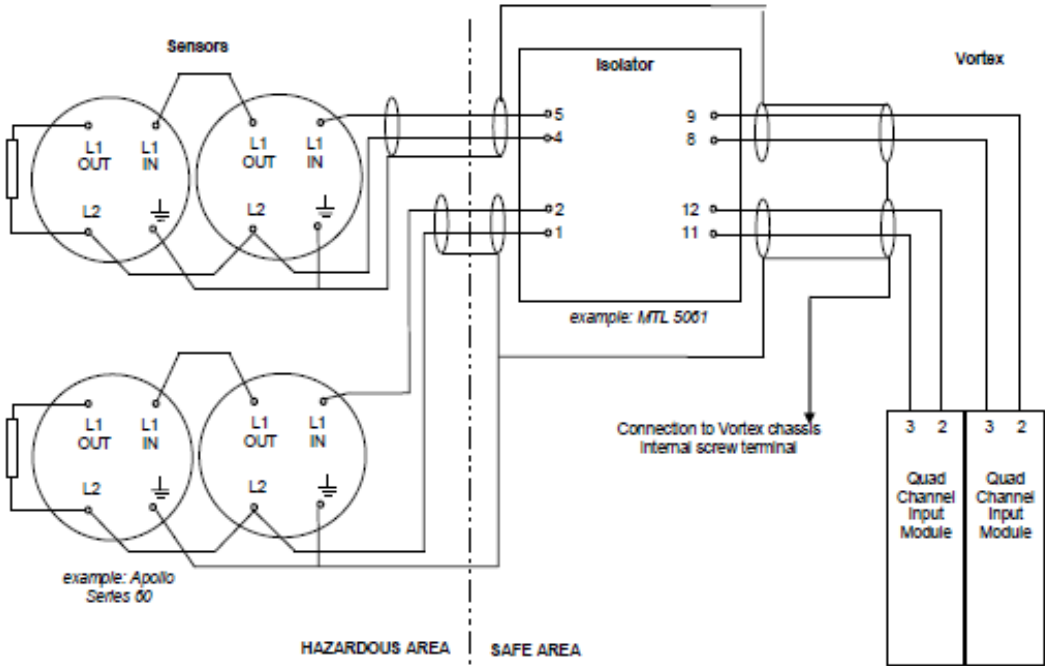

Diagram 5B

Fire sensor connection to Vortex via a galvanic isolator (dual).



Wiring Standards

Refer to section 3.6 for general cabling requirements.

In the UK and Europe the following standards apply regarding earthing and screens.

- Refer to BS EN60079-14 for requirements on the earthing arrangement of the barrier earthbar and the earthing of cable screens in the hazardous area.

Where galvanic isolators are used the connection of the 0V line to the chassis (at Vortex TP1 or at the external power supply if the power supply is non-isolated) and the chassis to earth must be of high quality, low resistance and high integrity.

For installing sounders and other signalling devices into hazardous environments refer to the device manufacturers data.

Warranty Statement

This equipment leaves our works fully tested. If within the warranty period of one year, the equipment is proved to be defective by reason of faulty workmanship or material, we undertake at our discretion either to repair or replace it free of charge, subject to the conditions below.

Warranty Procedure

To facilitate efficient processing of any claim, contact our customer support team on 01235 557711 with the following information:

- Your contact name, phone number, fax number and email address.
- Description and quantity of goods being returned, including any accessories.
- Instrument serial number(s).
- Reason for return.

Obtain a Returns form for identification and traceability purpose. This form may be downloaded from our website 'crowconsupport.com', along with a returns label, alternatively we can 'email' you a copy.

Instruments will not be accepted for warranty without a Crowcon Returns Number ("CRN"). It is essential that the address label is securely attached to the outer packaging of the returned goods.

Units returned to Crowcon as faulty and are subsequently found to be 'fault free' or requiring service, may be subject to a handling and carriage charge.

Warranty Disclaimer

The guarantee will be rendered invalid if the instrument is found to have been altered, modified, dismantled, or tampered with. The warranty does not cover misuse or abuse of the unit.

Any warranty on batteries may be rendered invalid if an unreasonable charging regime is proven.

Crowcon accept no liability for consequential or indirect loss or damage howsoever arising (including any loss or damage arising out of the use of the instrument) and all liability in respect of any third party is expressly excluded.

The warranty and guarantee does not cover the accuracy of the calibration of the unit or the cosmetic finish of the product. The unit must be maintained in accordance with the Operating and Maintenance Instructions.

Our liability in respect of defective equipment shall be limited to the obligations set out in the guarantee and any extended warranty, condition or statement, express or implied statutory or otherwise as to the merchantable quality of our equipment or its fitness for any particular purpose is excluded except as prohibited by statute. This guarantee shall not affect a customer's statutory rights.

For warranty and technical support enquiries please contact:

Customer Support

Tel +44 (0) 1235 557711

Fax +44 (0) 1235 557722

Email: customersupport@crowcon.com

A HALMA COMPANY

© Crowcon Detection Instruments Ltd 2015

**UK Office**

Crowcon Detection Instruments Ltd
 172 Brook Drive,
 Milton Park,
 Abingdon
 Oxfordshire
 OX14 4SD
 Tel: +44 (0) 1235 557700
 Fax: +44 (0) 1235 557749
 Email: sales@crowcon.com
 Website: www.crowcon.com

USA Office

Crowcon Detection Instruments Ltd
 1455 Jamike Ave, Suite 100
 Erlanger
 KY 41018
 Tel: +1 859 957 1039 or 1 800 527 6926
 Fax: +1 859 957 1044
 Email: salesusa@crowcon.com
 Website: www.crowcon.com

Netherlands Office

Crowcon Detection Instruments Ltd
 Vlambloem 129
 3068JG, Rotterdam
 Netherlands
 Tel: + 31 10 421 1232
 Fax: + 31 10 421 0542
 Email: eu@crowcon.com
 Website: www.crowcon.com

Singapore Office

Crowcon Detection Instruments Ltd
 Block 194, Pandan Loop
 #06-20 Pantech Industrial Complex
 Singapore 128383
 Tel: + 65 6745 2936
 Fax: +65 6745 0467
 Email: sales@crowcon.com.sg
 Website: www.crowcon.com

China Office

Crowcon Detection Instruments Ltd (Beijing)
 Unit 316, Area 1, Tower B, Chuangxin Building
 12 Hongda North Road,
 Beijing Economic Technological Development Area
 Beijing, China 100176
 Tel: +86 10 6787 0335
 Fax: +86 10 6787 4879
 Email: saleschina@crowcon.cn
 Website: www.crowcon.com

Crowcon reserves the right to change the design or specification of this product without notice